



**WACKER  
NEUSON**

Ersatzteilkatalog  
Spare parts catalog  
Catálogo de piezas de repuesto  
Catalogue de pièces de rechange

**Vibrationsplatte  
Vibratory plate  
Plancha vibratoria  
Plaque vibrante**

**DPU6555Heh**



Type	DPU6555Heh
Material Number	5100009636
Version	106
Language	de   en   es   fr



[www.wackerneuson.com](http://www.wackerneuson.com)

Copyright © 08.2022  
Wacker Neuson Produktion GmbH & Co. KG  
Printed in Germany.  
All rights reserved.

Ein Typenschild mit Typ, Artikelnummer, Version und Maschinen-Nummer ist an jedem Gerät angebracht. Die Daten von diesem Schild bitte notieren, damit sie auch bei Verlust oder Beschädigung des Schildes noch vorhanden sind. Der Typ, die Artikelnummer, die Versions-Nummer und die Maschinen-Nummer sind bei der Ersatzteilbestellung oder Nachfragen bezüglich Service-Informationen stets erforderlich.

Bei den in den Ersatzteillisten fettgedruckten Nummern handelt es sich um empfohlene Ersatzteile. Dies bedeutet, daß diese Teile bei normalen Anwendungsbedingungen natürlicher Abnutzung ausgesetzt sind und gelegentlich ersetzt oder überarbeitet werden müssen. Es wird geraten, diese Teile auf Lager bereit zu haben, um für Service-Arbeiten an diesem Gerät vorbereitet zu sein. Lagerbestände für diese und andere Teile, welche für ausgiebigere Reparaturarbeiten benötigt werden, können je nach Service-Gewohnheiten der einzelnen Kunden variieren.

Die Nummern meines Gerätes sind:

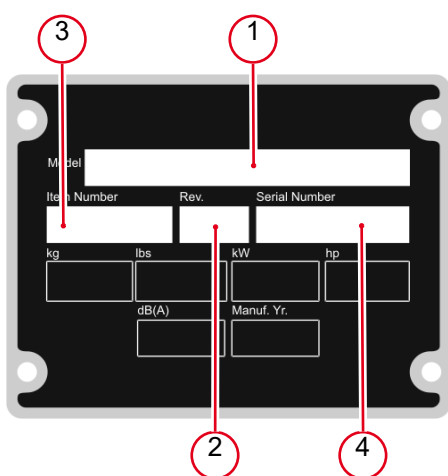

1. Typ
2. Version
3. Artikel-Nr.
4. Maschinen-Nr.

**Umrechnungstabelle**

Volumeneinheit	
1 ml	0.034 US fl.oz.
1 l	0.260 gal
Längeneinheit	
1 mm	0.039 in
1 m	3.280 ft
Gewicht	
1 kg	2.200 lbs
1 g	0.035 oz
Geschwindigkeit	
1 km/h	0.620 mph
Drehmoment	
1 Nm	0.740 ft.lbs

A nameplate listing the Model Number, Item Number, Revision, and Serial Number is attached to each unit. Please record the information found on this plate so it will be available should the nameplate become lost or damaged. When ordering parts or requesting service information, you will always be asked to specify the model, item number, revision number, and serial number of the unit.

Part Numbers appearing in boldface type are recommended spare parts. This means that these parts are subject to wear under normal operating conditions and may require periodic service or replacement. It is recommended that these items be stocked to meet the expected service requirements of this model. Actual stocking quantities of these and other parts used in more extensive repairs will depend on the service practices of each customer.

My machine's numbers are:

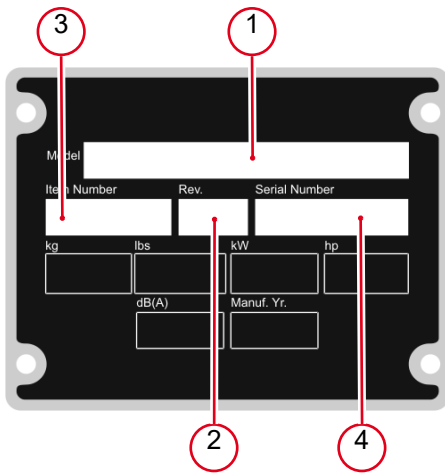

1. Model
2. Revision
3. Item No.
4. Serial No.

**Conversion table**

Volume unit	
1 ml	0.034 US fl.oz.
1 l	0.260 gal
Unit of length	
1 mm	0.039 in
1 m	3.280 ft
Weight	
1 kg	2.200 lbs
1 g	0.035 oz
Speed	
1 km/h	0.620 mph
Torque	
1 Nm	0.740 ft.lbs

Una placa de identificación con el modelo, número de referencia, nivel de revisión y número de serie ha sido añadida en cada máquina. Favor de anotar los datos en la placa en caso de que la placa de identificación sea destruida o perdida. En todos los pedidos para repuestos necesita siempre el modelo, el número de referencia, el nivel de revisión y el número de serie de la máquina en cuestión.

Los números de partes en negritas en las Listas Ilustradas de Partes son los repuestos recomendados, esto quiere decir que estas partes se desgastarán bajo circunstancias de funcionamiento normales y pueden requerir servicio periódico o su reemplazo. Se recomienda que el cliente mantenga un abastecimiento adecuado de estas partes para poder satisfacer la demanda requerida por el servicio a la máquina. La cantidad de repuestos que el cliente necesitará para reparaciones dependerá de la póliza de servicio de cada cliente.

Los números de mi máquina son:

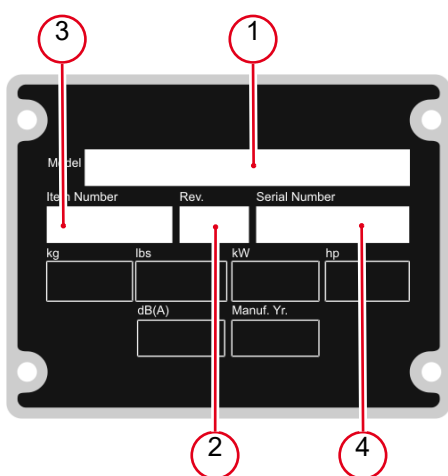

- 1. Modelo
- 2. Nivel de revisión
- 3. Número de referencia
- 4. Número de Serie

**Tabla de conversión**

Unidad de volumen	
1 ml	0.034 US fl.oz.
1 l	0.260 gal
Unidad de longitud	
1 mm	0.039 in
1 m	3.280 ft
Peso	
1 kg	2.200 lbs
1 g	0.035 oz
Velocidad	
1 km/h	0.620 mph
Par de apriete	
1 Nm	0.740 ft.lbs



Une plaque signalétique mentionnant le modèle, le numéro de référence, le niveau de revision et le numéro de série est fixée sur chaque machine. Veuillez noter les informations relevées sur cette plaque de façon à ce qu'elles soient toujours disponibles si la plaque signalétique venait à être perdue ou endommagée. Lorsque vous commandez des pièces détachées ou vous sollicitez des informations après-vente, on vous demandera toujours de préciser le modèle, le numéro de référence, le niveau de revision et le numéro de série de la machine.

Les numéros de pièces imprimés en caractères gras dans les Listes des Pièces Détachées de ce manuel sont les pièces détachées recommandées par la Wacker. Cela veut dire que ces pièces sont sujettes à usure dans des conditions de travail normales et peuvent nécessiter de l'entretien ou leur remplacement. Nous recommandons que vous disposiez d'un stock de ces pièces pour pouvoir satisfaire la demande d'entretien de cette machine. Le client doit décider lui-même de la quantité exacte de pièces de rechange qu'il disposera dans ses stocks.

Les numéros de ma machine son :

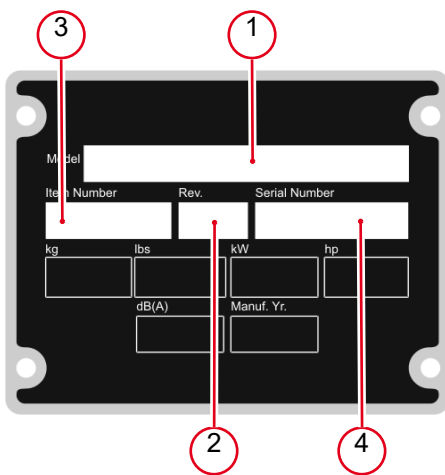

- 1. Typ
- 2. Version
- 3. Artikel-Nr.
- 4. Maschinen-Nr.

**Table de conversion**

Unité de volume	
1 ml	0.034 US fl.oz.
1 l	0.260 gal
Unité de longueur	
1 mm	0.039 in
1 m	3.280 ft
Poids	
1 kg	2.200 lbs
1 g	0.035 oz
Vitesse	
1 km/h	0.620 mph
Couple de serrage	
1 Nm	0.740 ft.lbs

Vibrationsplatte Vibration plate Plancha vibradora Plaque vibrante .....	12
-----------------------------------------------------------------------------------	----

Vibrationsplatte Vibration plate Plancha vibradora Plaque vibrante .....	14
-----------------------------------------------------------------------------------	----

Deichsel Skandinavien Ausführung Center pole scandinavia version Barra de mando escandinavia versión Timon scandinavie version .....	16
-----------------------------------------------------------------------------------------------------------------------------------------------	----

Obermasse Upper mass Masa superior Massa superieure .....	18
--------------------------------------------------------------------	----

Batteriedeckel Kpl. Battery cover cpl. Protección de batería Couvercle de batterie cpl. ....	22
-------------------------------------------------------------------------------------------------------	----

Batterieschutz Kpl. Battery protection cpl. Protección de batería cpl. Protection de batterie cpl. ....	24
------------------------------------------------------------------------------------------------------------------	----

Untermasse Baseplate Masa inferior Masse inferieure .....	26
--------------------------------------------------------------------	----

Erreger Exciter Excitador Excitatrice .....	28
------------------------------------------------------	----

Deichsel Kpl. Center pole cpl. Barra de mando cpl. Timon cpl. ....	32
-----------------------------------------------------------------------------	----

Deichselkopf Kpl. Center pole head cpl. Cabezal de mando cpl. Tête de timon cpl. ....	36
------------------------------------------------------------------------------------------------	----

Kupplung Kpl. Coupling cpl. Embrague cpl. Embrayage cpl. ....	38
------------------------------------------------------------------------	----

Fliehkraftkupplung Kpl. Centrifugal clutch cpl. Embrague centrifugo cpl. Embrayage centrifuge cpl. ....	40
------------------------------------------------------------------------------------------------------------------	----

Aufkleber Labels Calcomanías Autocollants .....	42
Aufkleber US Labels us Calcomanías us Autocollants us .....	44
Motor Engine Motor Moteur	
Kurbelgehäuse Crankcase Cárter Carter .....	46
Kurbelgehäuse Crankcase Cárter Carter .....	48
Kurbelwelle, Lagerflansch Crankshaft, bearing flange Cigüeñal, brida-rodamiento Vilebrequin, colletterette- .....	52
Nockenwelle Camshaft Arbol de levas Arbre à cames .....	54
Kolben, Pleuel, Zylinder Piston, connecting rod, cylinder Pistón, biela, cilindro Piston, bielle, cylindre .....	56
Zylinderkopf Cylinder head Culata Culasse .....	58
Ölpumpe, Regler Oil pump, governor Bomba de aceite, regulador Pompe à huile, régulateur .....	64
Ölablaß Oil drain Drenaje de aceite Raccord vidange d'huile .....	66
Steuerdeckel Command cover Tapa del mando Couvercle de commande .....	68

Stoßstange, Schwungrad  
Push rod, fly wheel  
Varilla de empuje, volante  
Poussoir, volant ..... 70

StartfüllungEinspritzausrüstung  
Extra fuel device, specialequipment  
Sobrealimentación, arranque -accesorios  
Surcharge, des extra ..... 72

Luftführung  
Air ducting  
Conducción de aire  
Carter ventilation ..... 76

Entlüftung,Drehzahlverstellung  
Breather, governor  
Ventilación, regulador derevoluciones  
Ventilation, régulateur de ..... 78

Kraftstoffsystem  
Fuel system  
Sistema de combustible  
Système d'essence ..... 82

Luftfilter  
Air cleaner  
Filtro del aire  
Filtre à air ..... 86

Abgasdämpfer  
Exhaust silencer  
Silenciador  
Silencieux ..... 88

Andrehkurbel  
Starting crank  
Manivela de arranque  
Manivelle de démarrage ..... 90

Abschaltautomatik Mech.  
Automatic shut-off mech.  
Cierre automático  
Interruption automatique ..... 92

Anschlußgehäuse  
Coupling housing  
Caja de conexión  
Carter de branchement ..... 94

Motorausrüstung EPA  
Engine equipment epa  
Equipamiento de motor epa  
Equipement moteur epa ..... 96

Starter, Generator  
Starter, generator  
Arrancador, generador  
Démarreur, générateur ..... 98



Ersatzteilsätze Spare parts kits Juegos de repuestos Jeu de pièces de rechange .....	102
-----------------------------------------------------------------------------------------------	-----

Zubehör  
Accessories  
Accesorios  
Accessoires

Anbauplatten-Satz Extension plate kit Juego de placa de extensión Jeu de elargisseur .....	104
-----------------------------------------------------------------------------------------------------	-----

Anbauplatten-Satz Extension plate kit Juego de placa de extensión Jeu de elargisseur .....	106
-----------------------------------------------------------------------------------------------------	-----

Anbauplatten-Satz Extension plate kit Juego de placa de extensión Jeu de elargisseur .....	108
-----------------------------------------------------------------------------------------------------	-----

Schraubensatz Set of screws Juego de tornillos Jeu de vis .....	110
--------------------------------------------------------------------------	-----

Gleitvorrichtung PGV DPU 6555 Urethane pad pgv dpu 6555 Placa de deslizamientopgv dpu 6555 Jeu de tapis en polyuréthane .....	112
----------------------------------------------------------------------------------------------------------------------------------------	-----

Andrehkurbel Rückschlagsicher Starting crank Manivela de arranque Manivelle de démarrage .....	114
---------------------------------------------------------------------------------------------------------	-----

Anbausatz Andrehkurbel Kit-mounting-starting crank Juego-instalación-manivela de arranque Jeu de montage-manivelle de .....	116
--------------------------------------------------------------------------------------------------------------------------------------	-----

Nachrüstsatz Riemenberuhiger Kit-retrofit belt guide Juego de modificaciónguía de correa Lot de rattrapage .....	118
---------------------------------------------------------------------------------------------------------------------------	-----

Nachrüstsatz Rental DPU6555 Kit-retrofit rental dpu6555 Juego de modificación rental dpu6555 Lot de rattrapage .....	120
-------------------------------------------------------------------------------------------------------------------------------	-----



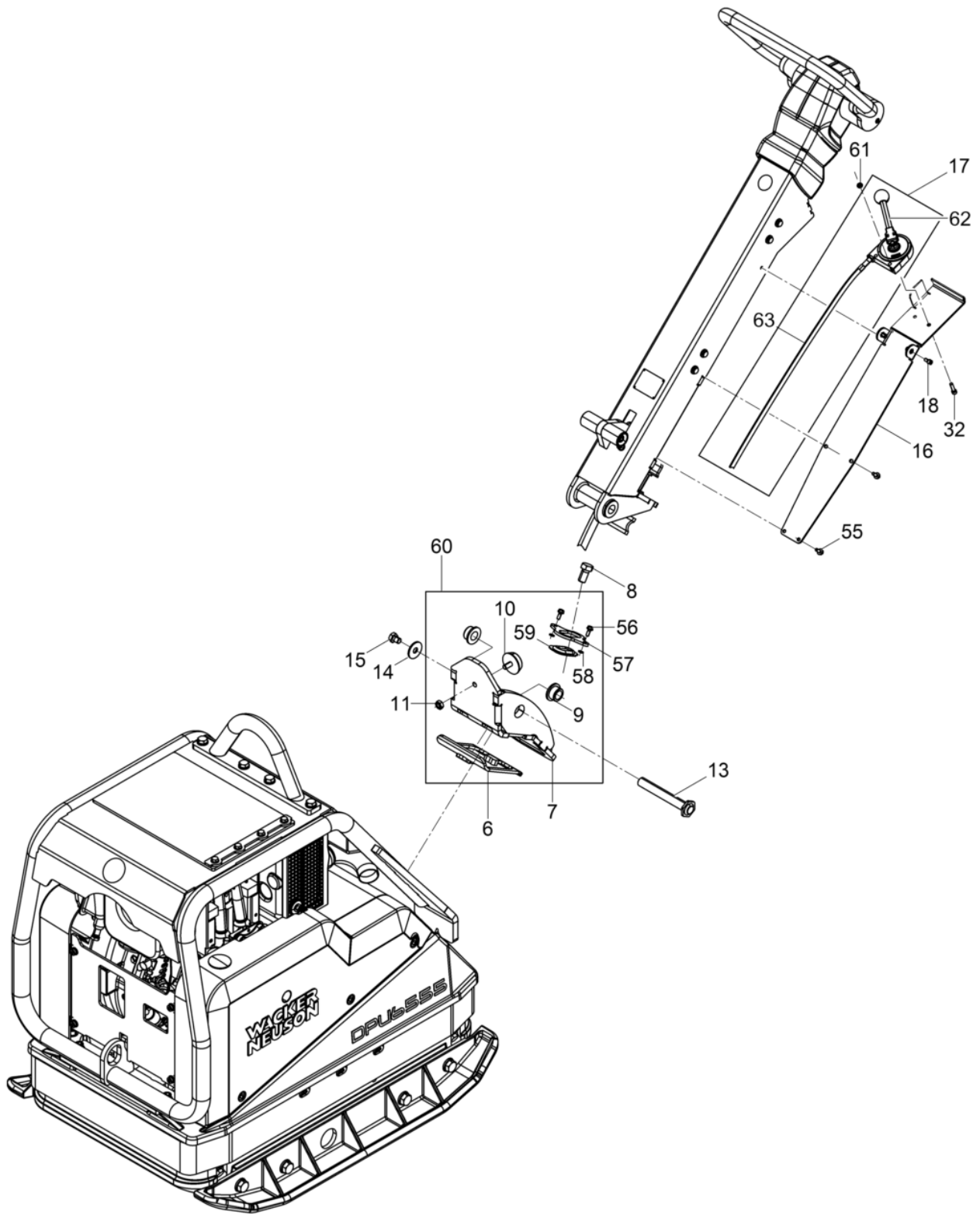

Pos. Item	Artikel Nr. Item no.	Pc.	Unit	Beschreibung Descripción	Description Description	Abm. Dim.	Norm Standard
						Drehmoment Torque	Schmierstoff Lubricant
6	5100010503	1	pc	Dichtungsprofil Junta	Profiled joint Joint d'étanchéité profilé		
7	5100003725	1	pc	Deichselbock Caballete de apoyo	Support Support		
8	5000011523	4	pc	Sechskantschraube Tornillo hexagonal	Hexagonal head cap screw Vis à tête hexagonale	M16 x 30 210Nm/155ft.lbs	DIN933
9	5100051256	2	pc	Buchse Buje	Bush Boîte		
10	5100005558	1	pc	Anschlagpuffer Amortiguador	Shockmount Silentbloc	50 x 18 M10 x 20	
11	5000010883	1	pc	Sechskantmutter Tuerca hexagonal	Hexagon nut Écrou hexagonal		
13	5100009632	1	pc	Achse Eje	Axle Axe		
14	5000010376	1	pc	Scheibe Arandela	Flat washer Rondelle	A13	DIN9021
15	5000014316	1	pc	Sechskantschraube Tornillo hexagonal	Hexagonal head cap screw Vis à tête hexagonale	M12 x 16 86Nm/63ft.lbs	DIN933
16	5100009950	1	pc	Deckblech Kpl. Cubierta de chapa cpl.	Cover plate cpl. Coife cpl.		
17	5100036296	1	pc	Betätigung Regulador	Control Commande		
18	5000011553	2	pc	Zylinderschraube Tornillo cilíndrico	Cheese head screw Vis à tête cylindrique		
32	5000011550	2	pc	Zylinderschraube Tornillo cilíndrico	Cheese head screw Vis à tête cylindrique	M6 x 25 10Nm/7ft.lbs	ISO4762
55	5000204408	4	pc	Schraube Tornillo	Screw Vis	DE M 6x 16	DIN7500
56	5000204408	2	pc	Schraube Tornillo	Screw Vis	DE M 6x 16	DIN7500
57	5100010505	1	pc	Blech Chapa	Plate Tôle		
58	5000010744	2	pc	Scheibe Arandela	Washer Rondelle	6,4	DIN433
59	5100010504	1	pc	Dichtung Junta	Gasket Joint		
60	5100010938	1	pc	Deichselbock Kpl. Caballete de apoyo cpl.	Support cpl. Support cpl.		
61	5000010880	2	pc	Sechskantmutter Tuerca hexagonal	Hexagon nut Écrou hexagonal		
62	5100049610	1	pc	Geber Acelerador	Throttle Levier regulateur		
63	5100049578	1	pc	Betätigung Accionamiento	Operating lever Boîtier de com. avec câble		

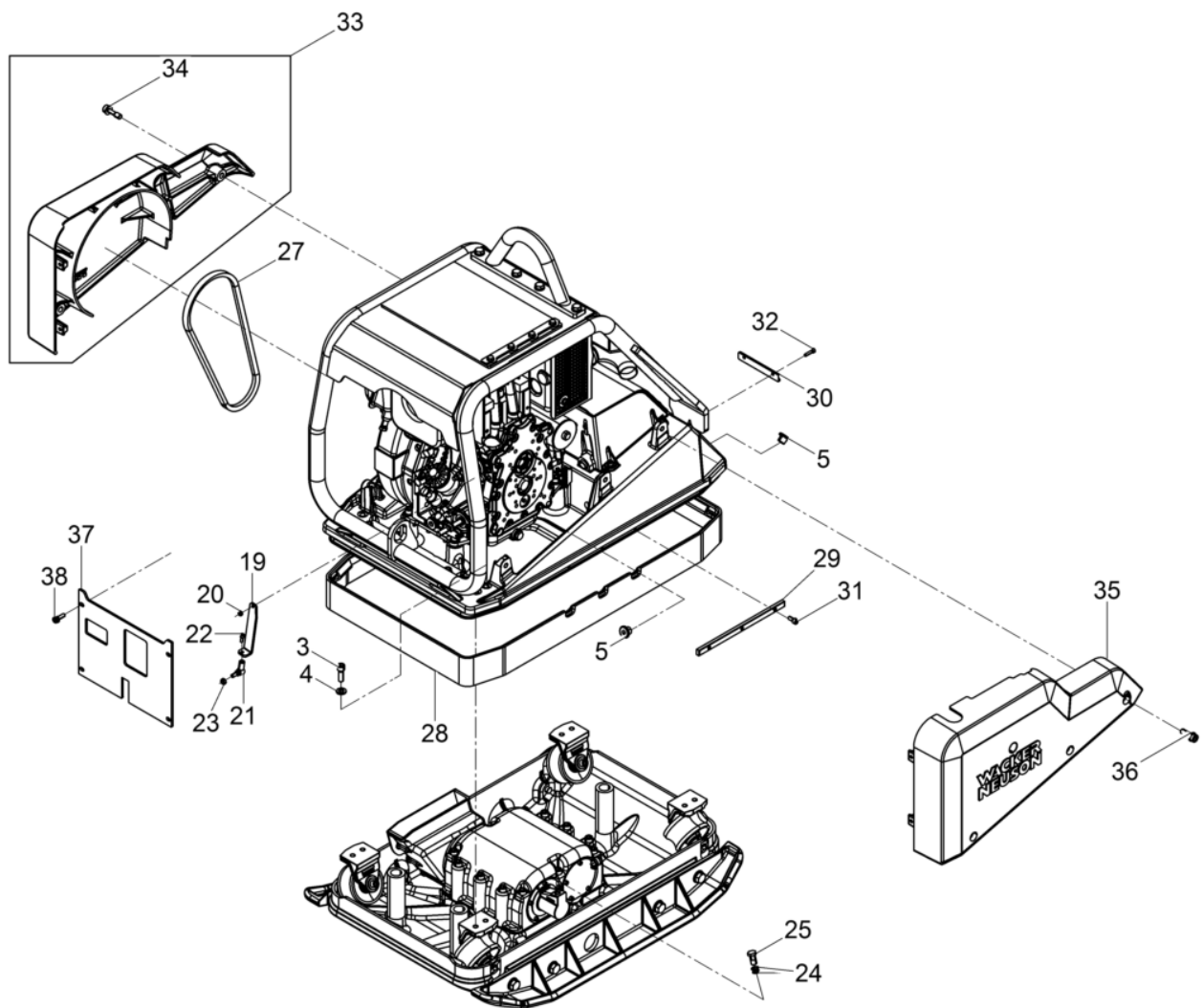

Pos. Item	Artikel Nr. Item no.	Pc.	Unit	Beschreibung Descripción	Description Description	Abm. Dim.	Norm Standard
						Drehmoment Torque	Schmierstoff Lubricant
3	5000011528	8	pc	Zylinderschraube Tornillo cilíndrico	Cheese head screw Vis à tête cylindrique	M12 x 35 86Nm/63ft.lbs	ISO4762
4	5000021465	8	pc	Sicherungsscheibe Arandela de seguridad	Lock washer Rondelle d'arrêt	HS12	
5	5000103880	2	pc	Rohrdurchführung Tubo de guía	Pipe guide Passage de tuyau		
19	5000103971	1	pc	Hebel Palanca	Lever Levier		
20	5000021679	1	pc	Sechskantmutter Tuerca hexagonal	Hexagon nut Écrou hexagonal	M6	DIN980
21	5000038403	1	pc	Winkelgelenk Articulación angular	Angular joint Jointure engulaire	AS13	DIN71802
22	5000011553	1	pc	Zylinderschraube Tornillo cilíndrico	Cheese head screw Vis à tête cylindrique	10Nm/7ft.lbs	
23	5000010882	1	pc	Sechskantmutter Tuerca hexagonal	Hexagon nut Écrou hexagonal		
24	5000012624	2	pc	Dichtring Anillo de junta	Gasket Bague d'étanchéité	A14 x 18	DIN7603
25	5000043201	1	pc	Hohlschraube Perno hueco	Banjo bolt Boulon creux à filet femelle	10-3	DIN7643
27	5000094072	1	pc	Keilriemen Correa en v	V-belt Courroie	17 x 1080	
28	5100009633	1	pc	Schürze Protección	Apron Tablier		
29	5000097110	2	pc	Leiste Listón	Bar Listeau		
30	5100009635	1	pc	Leiste Listón	Bar Listeau		
31	5000103962	6	pc	Zylinderschraube Tornillo cilíndrico	Cheese head screw Vis à tête cylindrique	M8 x 18 25Nm/18ft.lbs	ISO4762
32	5000011550	2	pc	Zylinderschraube Tornillo cilíndrico	Cheese head screw Vis à tête cylindrique	M6 x 25 10Nm/7ft.lbs	ISO4762
33	5100002778	1	pc	Riemenschutz Protección de la polea	Belt guard Protection de courroie		
34	5000220202	3	pc	Dünnschaftschraube Tornillo	Screw Vis	M12x 40	
35	5000220365	1	pc	Schutzhaube Cubierta de protección	Protective hood Capot de protection		
36	5000220325	3	pc	Sicherungsschraube Tornillo	Screw Vis	M 12x 35	
37	5000220190	1	pc	Schutzblech Chapa protectora	Guard plate Tôle de protection		
38	5000129420	4	pc	Zylindersicherungsschraube Tornillo de seguridad	Socket head cap screw Poignée supplémentaire		

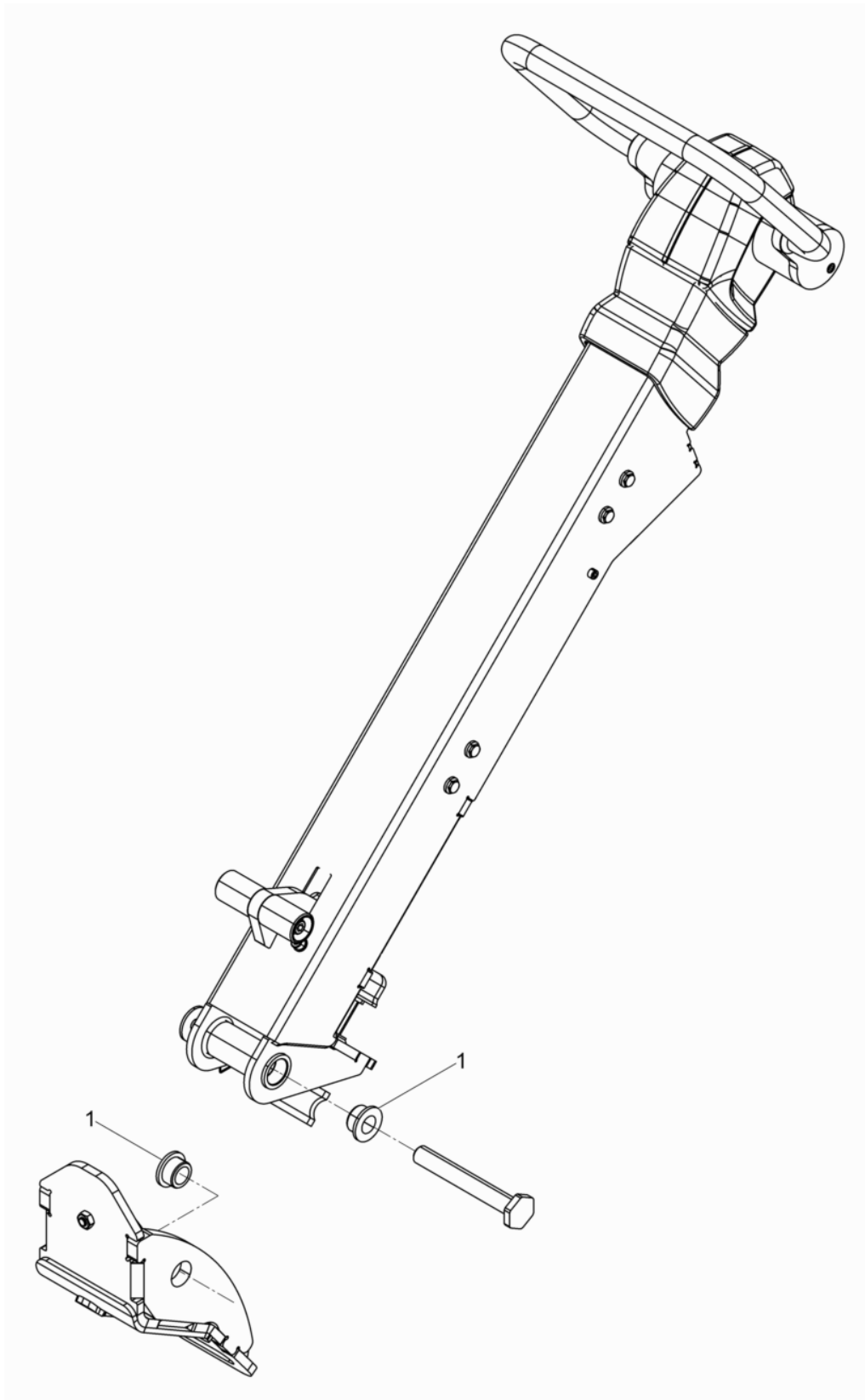

**DPU6555Heh****Deichsel Skandinavien Ausführung  
Center pole scandinavia version  
Barra de mando escandinavia versión  
Timon scandinavie version**

Pos. Item	Artikel Nr. Item no.	Pc.	Unit	Beschreibung Descripción	Description Description	Abm. Dim.	Norm Standard
						Drehmoment Torque	Schmierstoff Lubricant
1	5100042458	4	pc	Messingbuchse Buje de latón	Brass bush Boîte en laiton		



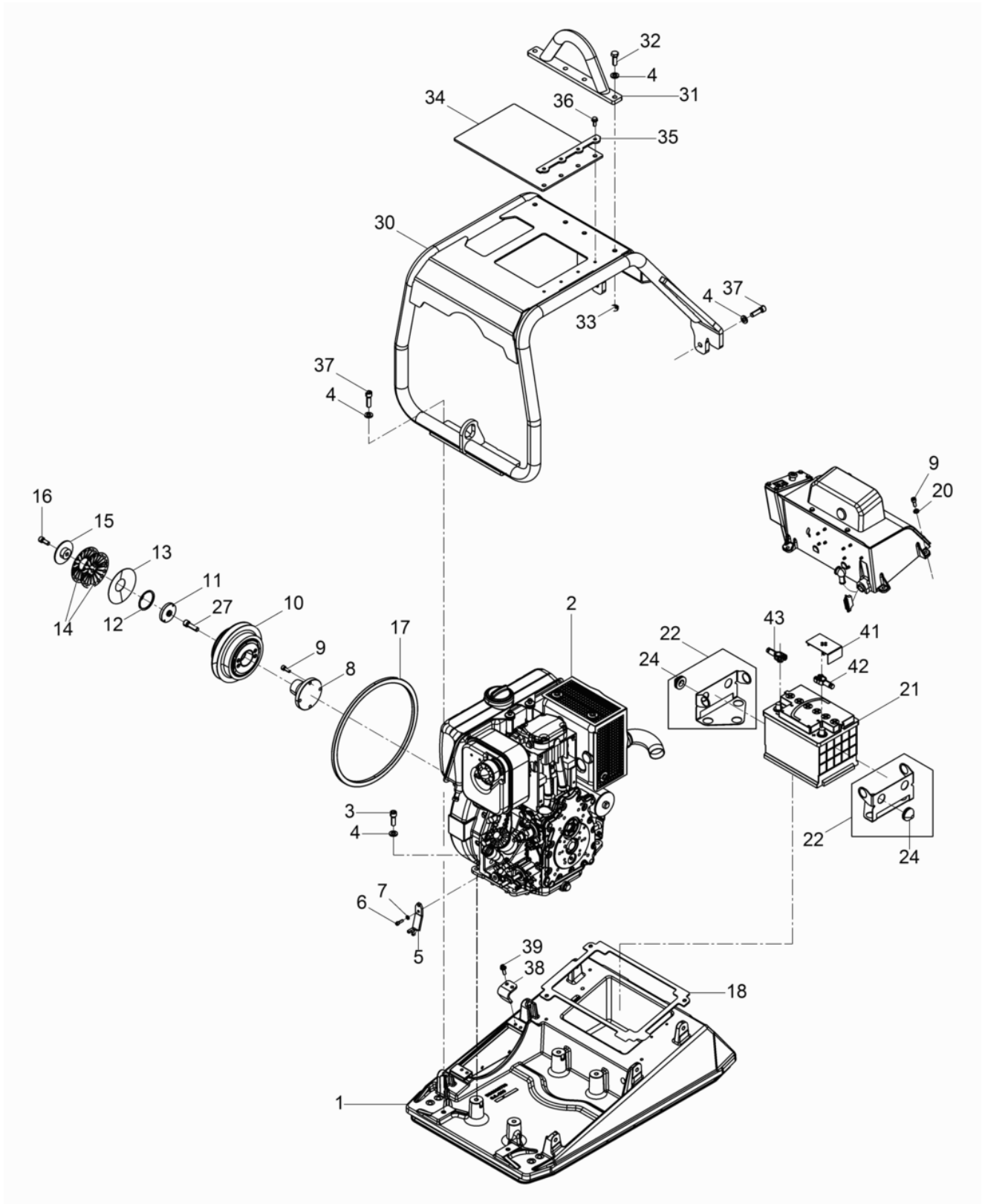

Pos. Item	Artikel Nr. Item no.	Pc.	Unit	Beschreibung Descripción	Description Description	Abm. Dim.	Norm Standard
						Drehmoment Torque	Schmierstoff Lubricant
1	5100003737	1	pc	Obermasse Masa superior	Upper mass Masse superieure		
2	5100043177	1	pc	Dieselmotor Motor diesel	Diesel engine Moteur diesel		
3	5000011528	4	pc	Zylinderschraube Tornillo cilíndrico	Cheese head screw Vis à tête cylindrique	M12 x 35 86Nm/63ft.lbs	ISO4762
4	5000021465	12	pc	Sicherungsscheibe Arandela de seguridad	Lock washer Rondelle d'arrêt	HS12	
5	5000103893	1	pc	Winkel Ángulo	Angle Coude		
6	5000011551	2	pc	Zylinderschraube Tornillo cilíndrico	Cheese head screw Vis à tête cylindrique	10Nm/7ft.lbs	
7	5000010624	2	pc	Scheibe Arandela	Flat washer Rondelle		
8	5000069900	1	pc	Flansch Brida	Flange Bride		
9	5000012629	8	pc	Zylinderschraube Tornillo cilíndrico	Cheese head screw Vis à tête cylindrique	25Nm/18ft.lbs	
10	5000102208	1	pc	Kupplung Kpl. Embrague cpl.	Coupling cpl. Embrayage cpl.		
11	5000058546	1	pc	Scheibe Disco	Disc Disque		
12	5000021147	1	pc	Sicherungsring Anillo de retención	Retaining ring Bague d'arrêt	60 x 2	DIN472
13	5000048273	1	pc	Dichtung Junta	Seal Joint		
14	5000048374	2	pc	Tellerfeder Resorte de platillo	Cup spring Ressort belleville		
15	5000058547	1	pc	Pilz Fungiforme	Button Butée		
16	5000011534	1	pc	Zylinderschraube Tornillo cilíndrico	Cheese head screw Vis à tête cylindrique	M10 x 30 49Nm/36ft.lbs	ISO4762
17	5000048539	1	pc	Dichtung Junta	Seal Joint		
18	5000220183	1	pc	Dichtung Junta de estanqueidad	Gasket Garniture		
20	5000010742	4	pc	Scheibe Arandela	Washer Rondelle		
21	5100021329	1	pc	Batterie Batería	Battery Batterie		
22	5100011287	2	pc	Batterieprotector Kpl. Protección de batería cpl.	Battery protection cpl. Protection de batterie cpl.		
24	5000124255	19	pc	Batteriepuffer Tope	Shockmount Tampon		
27	5100010091	1	pc	Zylinderschraube Tornillo cilíndrico	Cheese head screw Vis à tête cylindrique	M12x 40 86Nm/63ft.lbs	
30	5000220379	1	pc	Schutzrahmen Armazón de protección	Protective frame Cadre protection		
31	5000099055	1	pc	Öse Punto de izaje	Hook Crochet		
32	5000011422	4	pc	Sechskantschraube Tornillo hexagonal	Hexagonal head cap screw Vis à tête hexagonale	M12 x 35 86Nm/63ft.lbs	DIN933
33	5000010366	4	pc	Sechskantmutter Tuerca hexagonal	Hexagon nut Écrou hexagonal	M12X1.75	DIN985
34	5000099535	1	pc	Platte Placa	Plate Plaque		

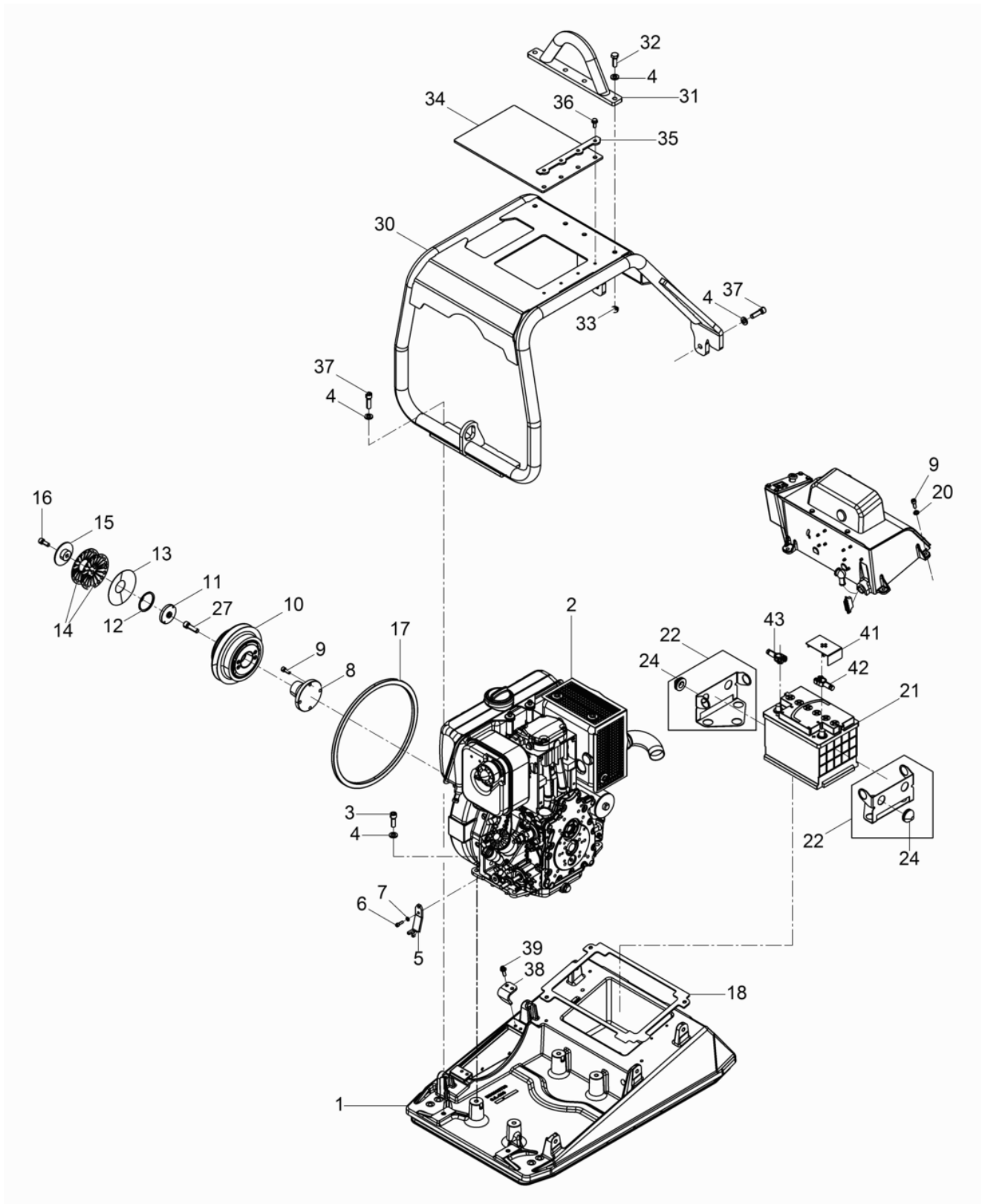

Pos. Item	Artikel Nr. Item no.	Pc.	Unit	Beschreibung Descripción	Description Description	Abm. Dim.	Norm Standard
						Drehmoment Torque	Schmierstoff Lubricant
35	5000099047	1	pc	Leiste Listón	Bar Listeau		
36	5000105944	4	pc	Schraube Tornillo	Screw Vis	DE M8 x 20	DIN7500
37	5000019244	4	pc	Zylinderschraube Tornillo cilíndrico	Cheese head screw Vis à tête cylindrique	M12 x 40 120Nm/89ft.lbs	ISO4762
38	5000220334	2	pc	Winkel Angulo	Angle Angle		
39	5000129420	4	pc	Zylindersicherungsschraube Tornillo de seguridad	Socket head cap screw Poignée supplémentaire		
41	5100011307	1	pc	Pluspol-Abdeckung Cubierta	Positive pol cover Couverture		
42	5100015202	1	pc	Polklemme Pluspol Terminal de polo positivo	Pole terminal positive Borne polaire positive		
43	5100015203	1	pc	Polklemme Minuspol Terminal de polo negativo	Pole terminal negative Borne polaire negative		

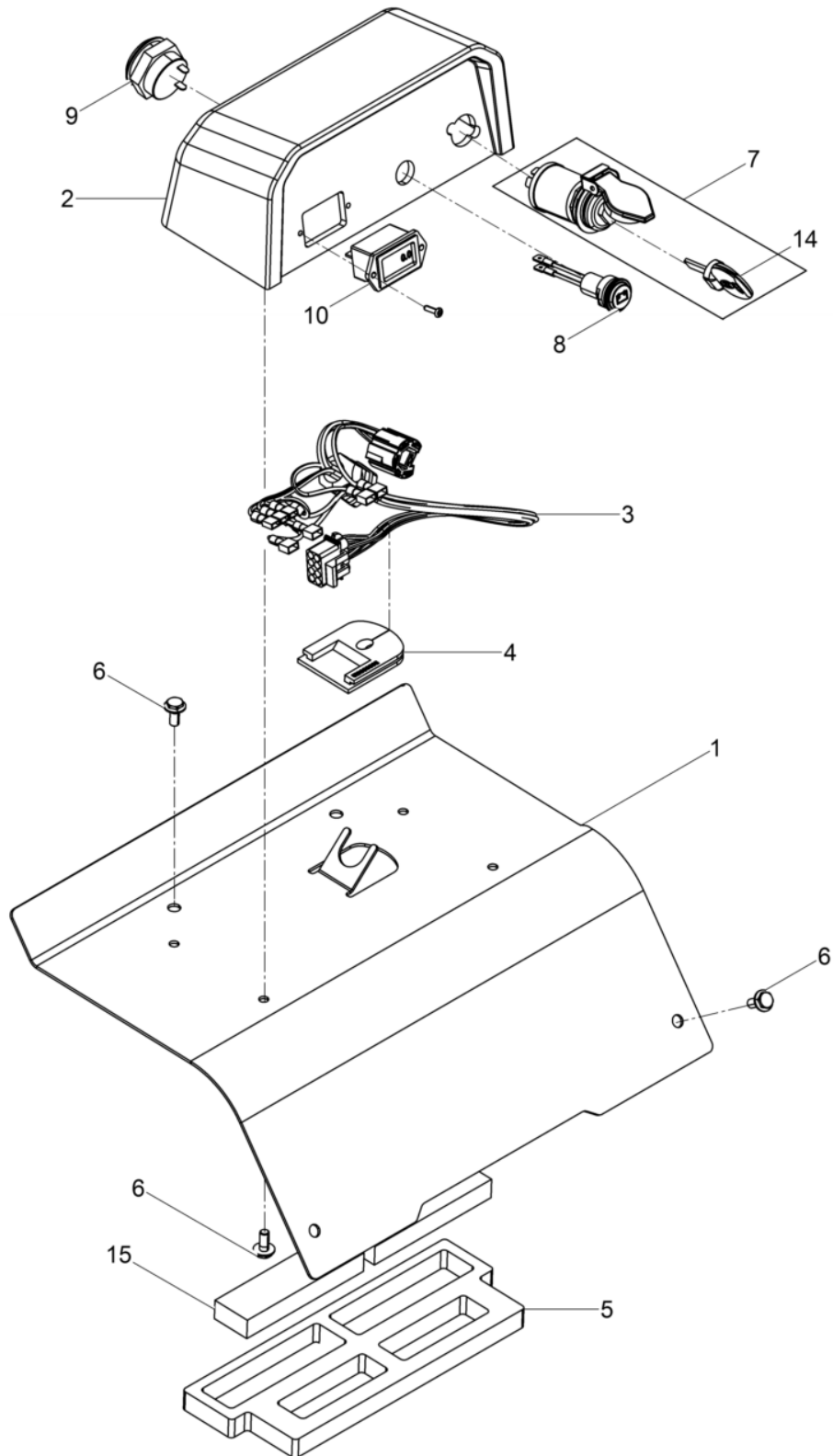

Pos. Item	Artikel Nr. Item no.	Pc.	Unit	Beschreibung Descripción	Description Description	Abm. Dim.	Norm Standard
						Drehmoment Torque	Schmierstoff Lubricant
1	5100020821	1	pc	Batteriedeckel Protección de batería	Battery cover Couvercle de batterie		
2	5100010085	1	pc	Gehäuse Carcasa	Housing Carter		
3	5100009620	1	pc	Spiralkabel Cable espiral	Helix cable Câble spirale		
4	5100009911	1	pc	Dichtung Junta	Gasket Joint		
5	5100020556	1	pc	Kissen Für Batterie Almohadilla	Insulating cushion Coussin		
6	5000210194	8	pc	Sicherungsschraube Tornillo	Corrugated-head screw Vis		
7	5100011296	1	pc	Zündanlassschalter Interruptor de arranque	Ignition starter switch Interrupteur démarreur		
8	5000129797	1	pc	LED Leuchte Diodo	Led Diode luminescente		
9	5000220234	1	pc	Signalgeber Señal acústica	Acoustic signal Signal acoustique		
10	5100011309	1	pc	Betriebsstundenzähler Carter del motor	Working hour meter Carter de moteur		
14	5000220118	1	pc	Schlüssel Llave	Key Clé		
15	5100020618	2	pc	Filtermatte Esteras filtrante	Filter mat Élément filtrant		

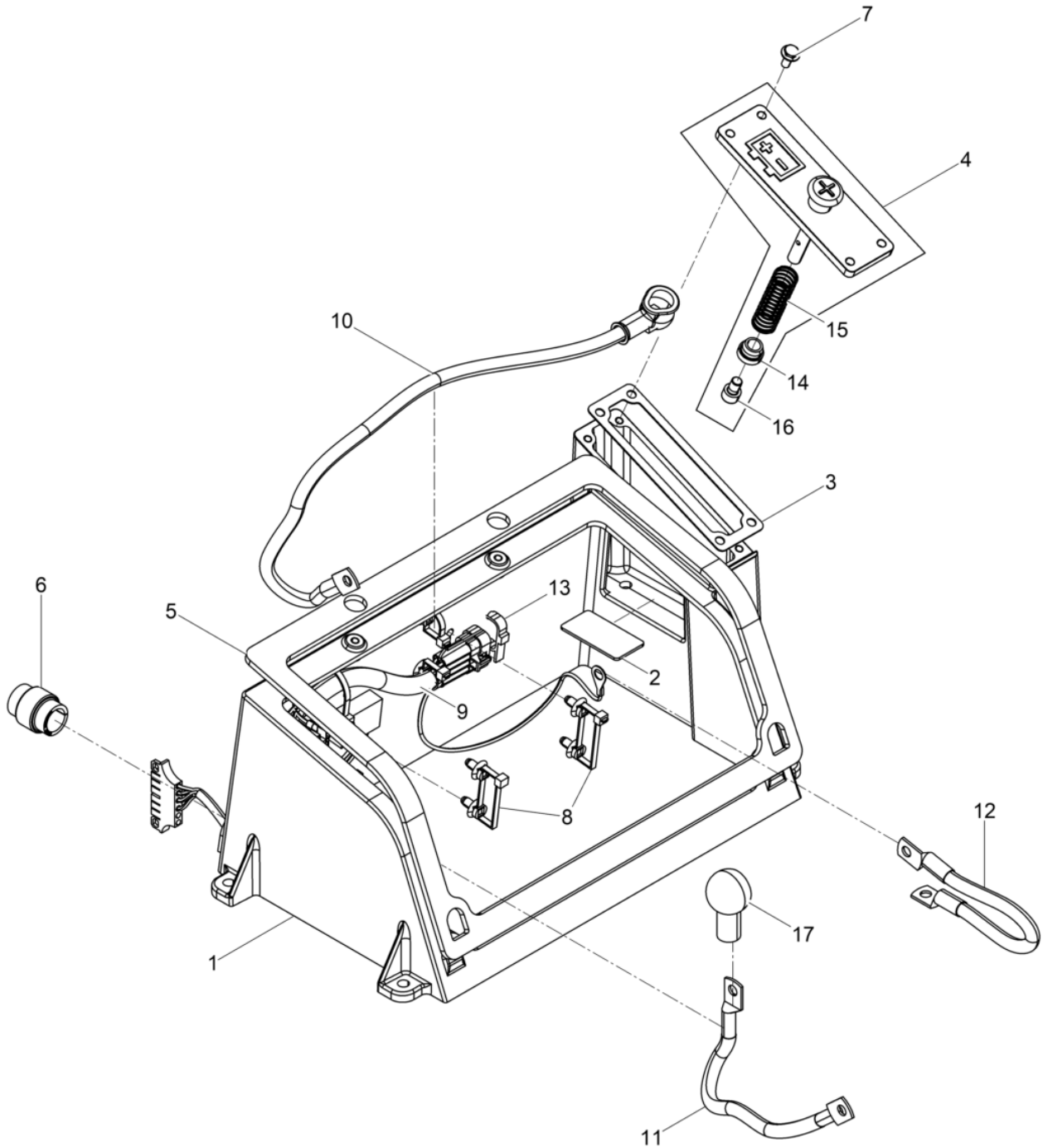

Pos. Item	Artikel Nr. Item no.	Pc.	Unit	Beschreibung Descripción	Description Description	Abm. Dim.	Norm Standard
						Drehmoment Torque	Schmierstoff Lubricant
1	5100011288	1	pc	Batterieschutz Protección de batería	Battery protection Protection de batterie		
2	5100010149	1	pc	Pad Cojín	Pad Coussin		
3	5000216678	1	pc	Dichtung Junta de estanqueidad	Gasket Garniture		
4	5100011304	1	pc	Starthilfe Kpl. Embolo buzo cpl.	Starting device cpl. Fouloir plongeur cpl.		
5	5000220173	1	pc	Dichtung Junta de estanqueidad	Gasket Garniture		
6	5000220432	1	pc	Einsatz Inserto	Insert Insertion		
7	5000210194	4	pc	Sicherungsschraube Tornillo	Corrugated-head screw Vis		
8	5100011341	9	pc	Kabelbinder Fijación	Tie cable Attache		
9	5100009683	1	pc	Kabelbaum Mazo de cables	Cable harness Harnais de câbles		
10	5100010865	1	pc	Fremdstarterkabel Cable	Battery boost cable Câble		
11	5100015100	1	pc	Plus-Pol-Leitung Cable polo positivo	Positive pole strap Ligne borne positive		
12	5100010866	1	pc	Minus-Pol-Leitung Cable polo negativo	Negative pole strap Ligne borne négative		
13	5000047388	1	pc	Kabelbinder Fijación de cables	Zip tie Attache de câble		
14	5100009601	1	pc	Buchse Buje	Bush Boîte		
15	5100011308	1	pc	Druckfeder Resorte de compresión	Compression spring Ressort de pression	1x17,5x100x8,5	
16	5000013574	1	pc	Zylinderschraube Tornillo cilindrico	Cheese head screw Vis à tête cylindrique	25Nm/18ft.lbs	
17	5000058696	1	pc	Verschlusskappe Tapa de cierre	Nose cap Chape de fermeture		

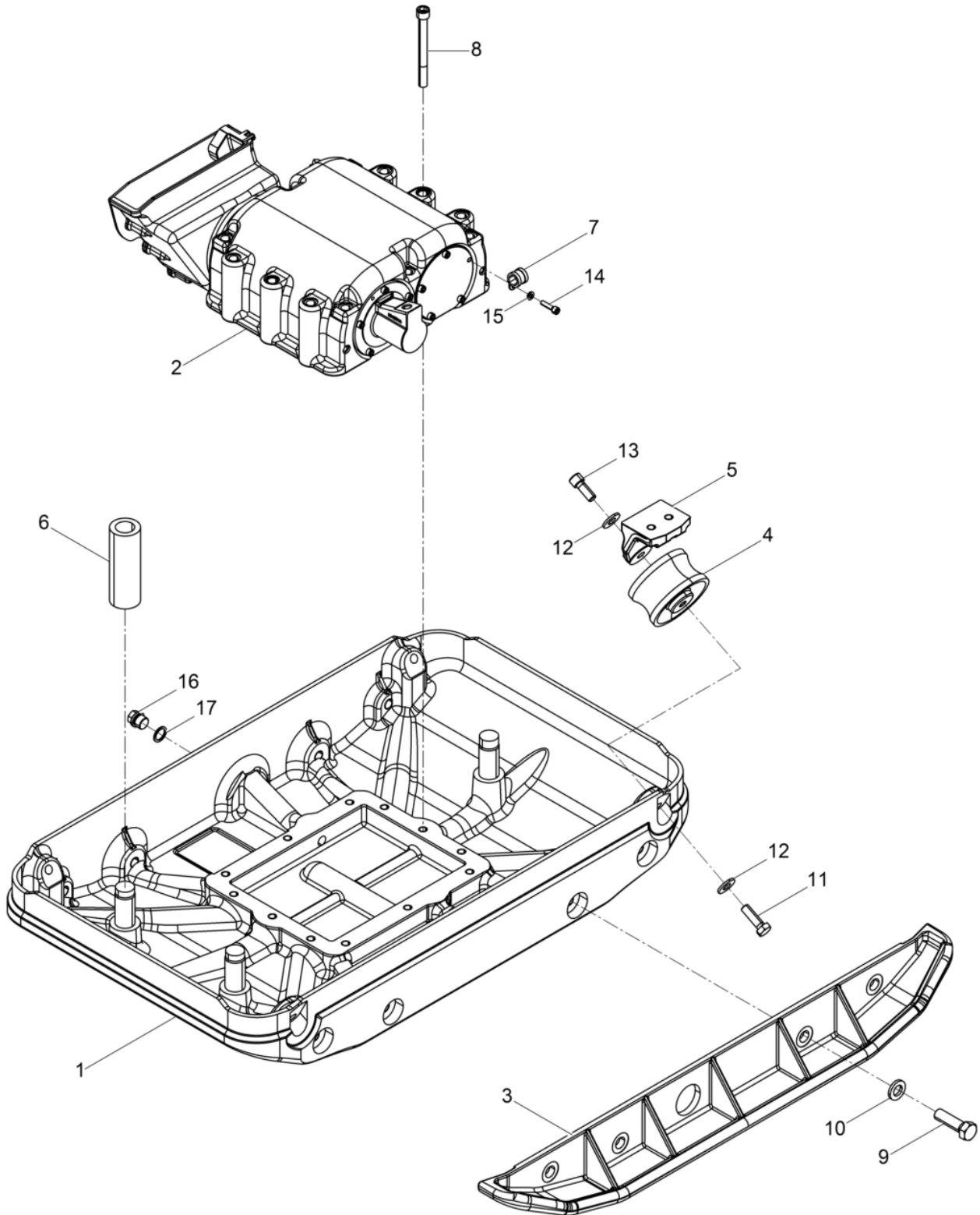

Pos. Item	Artikel Nr. Item no.	Pc.	Unit	Beschreibung Descripción	Description Description	Abm. Dim.	Norm Standard
						Drehmoment Torque	Schmierstoff Lubricant
1	5000102083	1	pc	Untermasse Masa inferior	Baseplate Masse inferieure		
2	5000220084	1	pc	Erreger Kpl. Excitador cpl.	Exciter cpl. Excitateur cpl.		
3	5000044442	2	pc	Anbauplatte Placa de extensión	Extension plate Elargisseur	8 cm	
4	5002004814	4	pc	Gimmetall-Kerblager Mit Bund Amortiguador	Shockmount Silentbloc	100 x 58	
5	5000102105	4	pc	Pufferbock Soporte tope	Support Support d'amortisseur		
6	5000034442	3	pc	Dämpfungsbuchse Buje	Bushing Douille		
7	5000017123	1	pc	Rohrschelle Abrazadera	Pipe clamp Collier pour tuyau		
8	5000094518	12	pc	Zylinderschraube Tornillo cilíndrico	Cheese head screw Vis à tête cylindrique	M12 x 120 120Nm/89ft.lbs	ISO4762
9	5000039191	8	pc	Sechskantschraube Tornillo hexagonal	Hexagonal head cap screw Vis à tête hexagonale	M16 x 1,5 x 55 210Nm/155ft.lbs	DIN961
10	5000021988	8	pc	Sicherungsscheibe Arandela de seguridad	Lock washer Rondelle d'arrêt	HS16	
11	5000011421	4	pc	Sechskantschraube Tornillo hexagonal	Hexagonal head cap screw Vis à tête hexagonale	M12 x 40 86Nm/63ft.lbs	DIN933
12	5000031565	8	pc	Spannscheibe Arandela elástica	Lockwasher Rondelle de ressort	12	DIN6796
13	5000011529	4	pc	Zylinderschraube Tornillo cilíndrico	Cheese head screw Vis à tête cylindrique	M12 x 30 86Nm/63ft.lbs	ISO4762
14	5000011550	1	pc	Zylinderschraube Tornillo cilíndrico	Cheese head screw Vis à tête cylindrique	M6 x 25 10Nm/7ft.lbs	ISO4762
15	5000010624	1	pc	Scheibe Arandela	Flat washer Rondelle		
16	5000068222	1	pc	Verschlusschraube Tapón roscado	Plug (threaded) Bouchon		
17	5000019156	1	pc	Dichtring Anillo de junta	Gasket Bague d'étanchéité		
19	5000219702	1	pc	Flansch Bride	Flange Bride		

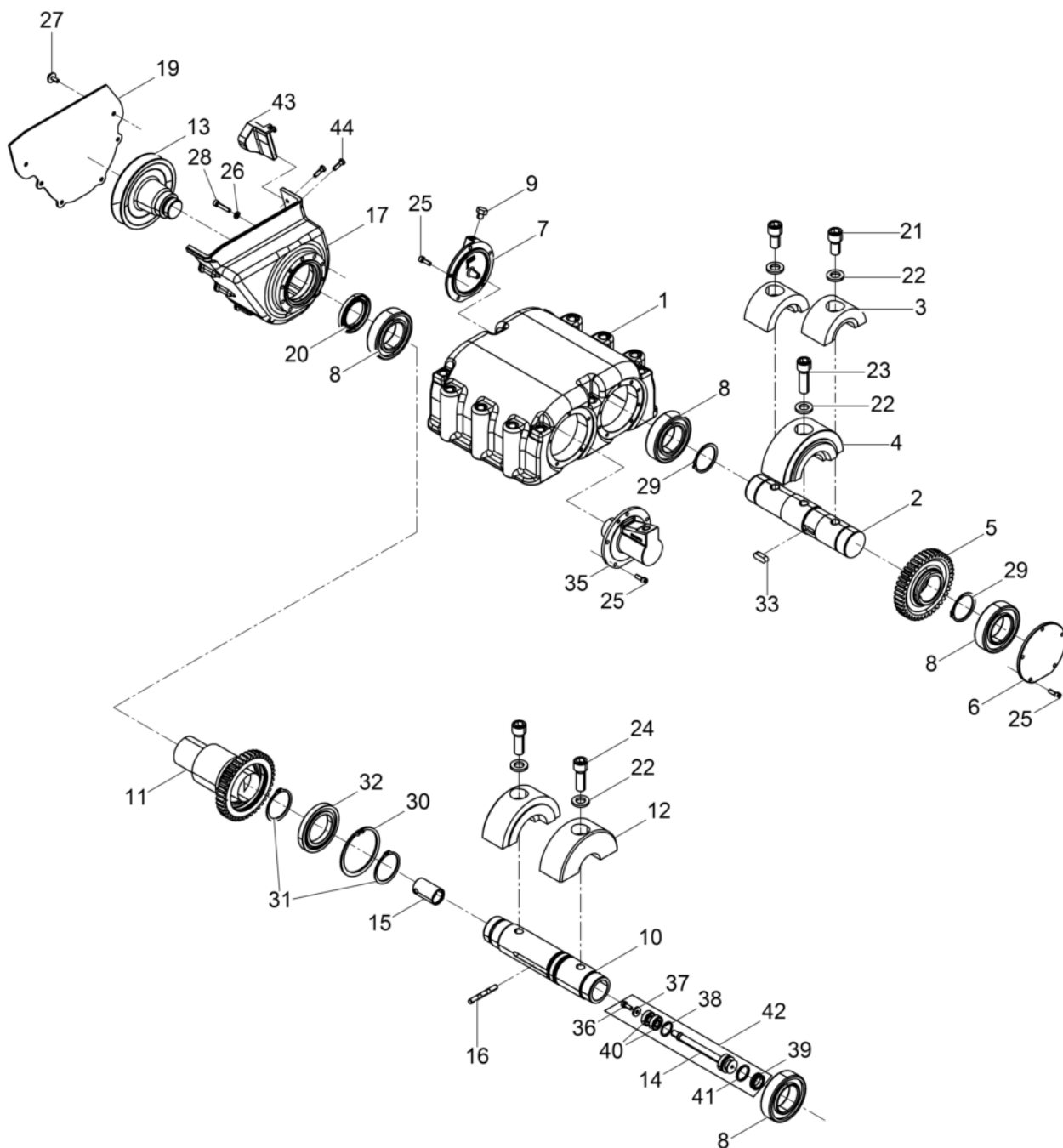

Pos. Item	Artikel Nr. Item no.	Pc.	Unit	Beschreibung Descripción	Description Description	Abm. Dim.	Norm Standard
						Drehmoment Torque	Schmierstoff Lubricant
1	5000099059	1	pc	Erregergehäuse Carcasa del excitador	Exciter housing Carter excitateur		
2	5000220059	1	pc	Welle Árbol	Shaft Arbre		
3	5000220082	2	pc	Unwucht Masa excéntrica	Eccentric weight Balourd		
4	5000220110	1	pc	Unwucht Masa excéntrica	Eccentric weight Balourd		
5	5000039116	1	pc	Zahnrad Engranaje	Gear wheel Roue dentée		
6	5000039110	1	pc	Deckel Tapa	Cover Couvercle		
7	5000102144	1	pc	Belüftungsdeckel Tapa de ventilación	Vent cover Couvercle d'aeration		
8	5000103469	4	pc	Zylinderrollenlager Rodamiento cilíndricos	Cylindrical roller bearing Roulement à rouleaux		
9	5001103030	1	pc	Entlüftungsschraube Tornillo de purga	Vent screw Vis d'évacuation d'air		
10	5000220077	1	pc	Welle Árbol	Shaft Arbre		
11	5000220053	1	pc	Verstellhülse Husillo de regulación	Adjusting sleeve Douille de réglage		
12	5000220083	2	pc	Unwucht Masa excéntrica	Eccentric weight Balourd		
13	5000129859	1	pc	Keilriemenscheibe Polea en v	V-belt pulley Poulie à courroie		
14	5000220079	1	pc	Bolzen Perno	Bolt Boulon		
15	5000220106	1	pc	Schaltbolzen Perno fijador	Indexing bolt Boulon		
16	5000043382	1	pc	Schaltstift Espiga de mando	Tripping pin Broche de manoeuvre		
17	5000201522	1	pc	Schutzkasten Caja de protección	Protective box Boitier de protection		
19	5000104124	1	pc	Blech Chapa	Plate Tôle		
20	5000048854	1	pc	Wellendichtring Anillo de retén radial	Rotary shaft seal Bague d'étanchéité	48 x 72 x 7,4	
21	5000044634	2	pc	Zylinderschraube Tornillo cilíndrico	Cheese head screw Vis à tête cylindrique	M16 x 30 295Nm/218ft.lbs	ISO4762
22	5000021988	5	pc	Sicherungsscheibe Arandela de seguridad	Lock washer Rondelle d'arrêt	HS16	
23	5000043812	1	pc	Zylinderschraube Tornillo cilíndrico	Cheese head screw Vis à tête cylindrique	M16 x 50 295Nm/218ft.lbs	ISO4762
24	5000126300	2	pc	Zylinderschraube Tornillo cilíndrico	Cheese head screw Vis à tête cylindrique	M16 x 45 295Nm/218ft.lbs	ISO4762
25	5000011552	14	pc	Zylinderschraube Tornillo cilíndrico	Cheese head screw Vis à tête cylindrique	M6 x 18 10Nm/7ft.lbs	ISO4762
26	5000010624	9	pc	Scheibe Arandela	Flat washer Rondelle		
27	5100009501	6	pc	Kombi-Schraube Tornillo	Screw Vis	M6 x 16 10Nm/7ft.lbs	
28	5000011549	9	pc	Zylinderschraube Tornillo cilíndrico	Cheese head screw Vis à tête cylindrique	M6 x 30 10Nm/7ft.lbs	ISO4762
29	5002006113	2	pc	Sicherungsring Anillo de retención	Retaining ring Bague d'arrêt		

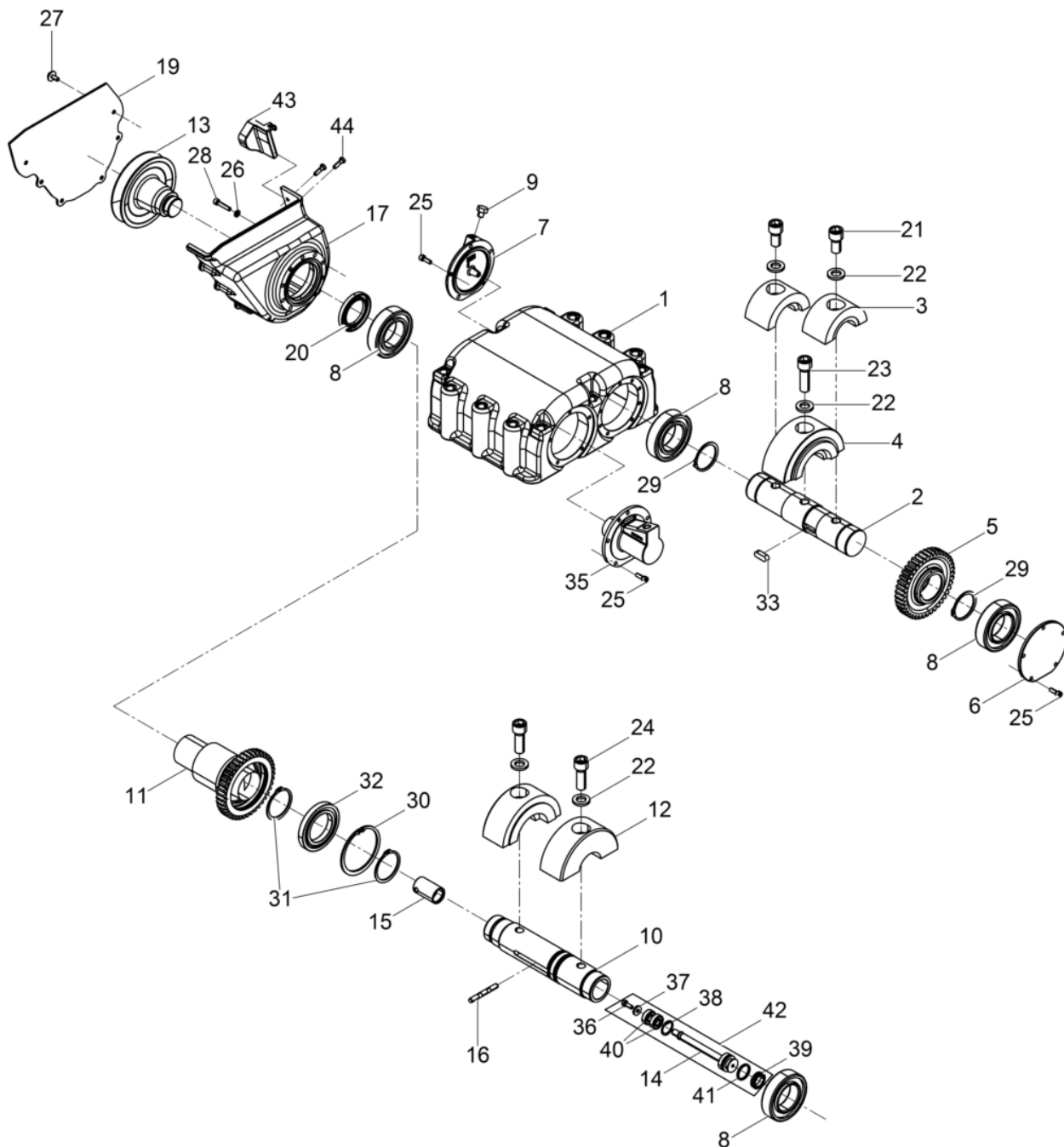

Pos. Item	Artikel Nr. Item no.	Pc.	Unit	Beschreibung Descripción	Description Description	Abm. Dim.	Norm Standard
						Drehmoment Torque	Schmierstoff Lubricant
30	5002007057	1	pc	Sicherungsring Anillo de retención	Retaining ring Bague d'arrêt	90 x 3	DIN472
31	5002004822	2	pc	Sicherungsring Anillo de retención	Retaining ring Bague d'arrêt	55 x 2	DIN471
32	5000220133	1	pc	Rillenkugellager Rodamiento a bolas	Grooved ball bearing Roulement rainuré à billes		DIN625
33	5002001399	1	pc	Passfeder Chaveta	Fitting key Clavette	A10 x 8 x 28	DIN6885
35	5000048604	1	pc	Zylinderdeckel Tapa del cilindro	Cylinder cover Couvercle de cylindre		
36	5000124717	1	pc	Scheibe Arandela	Washer Rondelle		
37	5000014663	1	pc	Sechskantschraube Tornillo hexagonal	Hexagonal head cap screw Vis à tête hexagonale	M6 x 16 10Nm/7ft.lbs	DIN933
38	5000220384	1	pc	Sicherungsring Anillo de retención	Retaining ring Bague d'arrêt	26x 1,20	DIN472
39	5000043203	1	pc	Gummilippenring Reten labial de goma	Lip seal ring Bague en caoutchouc	30 x 20 x 6	
40	5000220383	2	pc	Rillenkugellager Rodamiento a bolas	Grooved ball bearing Roulement rainuré à billes		DIN625
41	5002006991	1	pc	O-Ring Anillo-o	O-ring Bague-o	24 x 3	
42	5000220081	1	pc	Bolzen Kpl. Perno cpl.	Bolt cpl. Boulon cpl.		
43	5100003656	1	pc	Riemenberuhiger Guía de correa	Belt guide Guide-courroie		
44	5100013871	2	pc	Linsenkopfschraube Tornillo gota de sebo	Oval head screw Vis noyée lentiforme	6 x 20	

Deichsel Kpl.  
Center pole cpl.  
Barra de mando cpl.  
Timon cpl.

DPU6555HeH

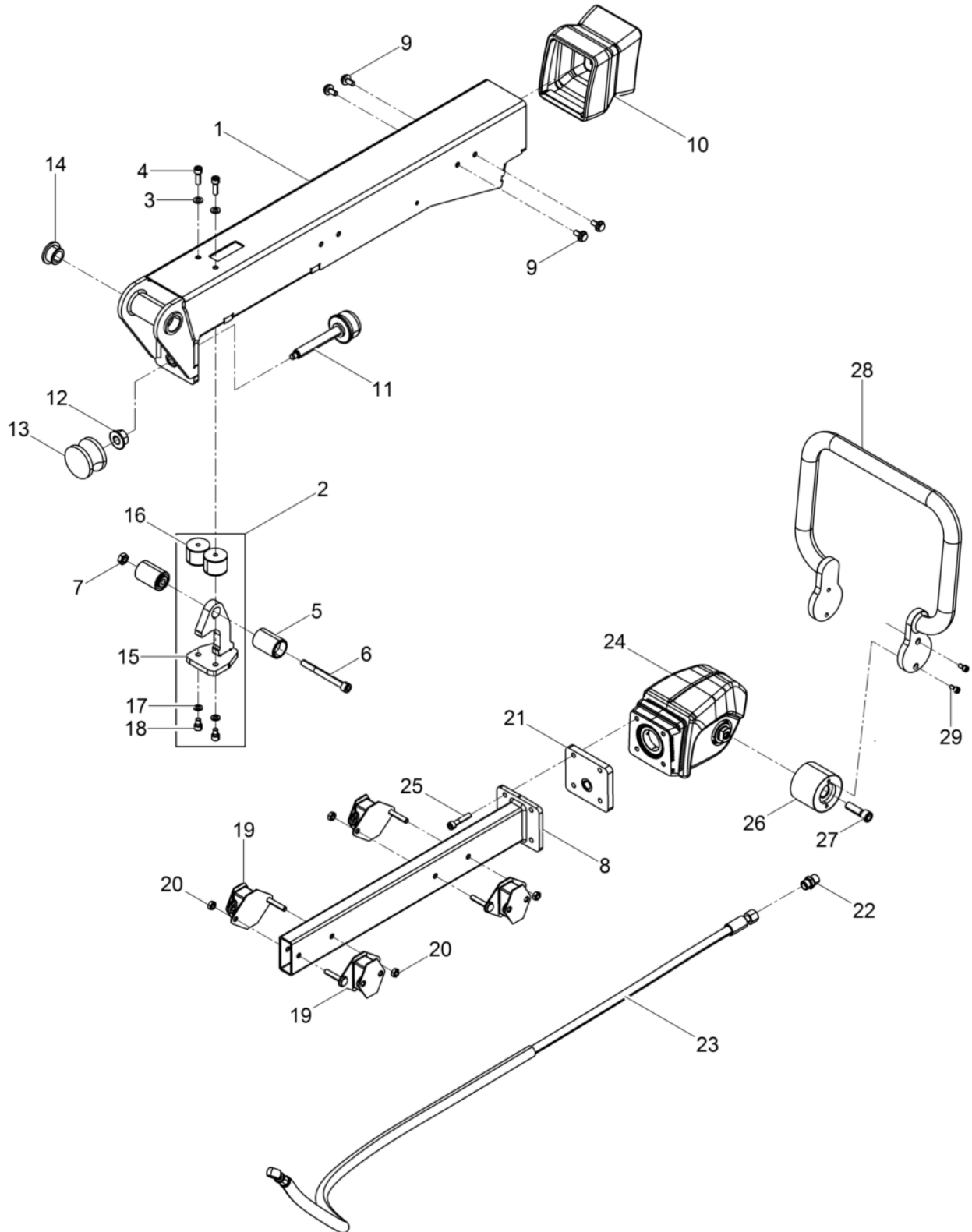

Pos. Item	Artikel Nr. Item no.	Pc.	Unit	Beschreibung Descripción	Description Description	Abm. Dim.	Norm Standard
						Drehmoment Torque	Schmierstoff Lubricant
1	5100009952	1	pc	Deichselrohr Barra de mando tubo	Center pole tube Timon tube		
2	5100005543	1	pc	Arretierung Dispositivo de retención	Lock Dispositif d'arrêt		
3	5000010622	2	pc	Scheibe Arandela	Flat washer Rondelle		
4	5000013574	2	pc	Zylinderschraube Tornillo cilíndrico	Cheese head screw Vis à tête cylindrique		
5	5100002007	2	pc	Arretierungsgriff Empuñadura de retención	Retaining handle Poignée d'arrêt		
6	5000037090	1	pc	Zylinderschraube Tornillo cilíndrico	Cheese head screw Vis à tête cylindrique	M10 x 100 49Nm/36ft.lbs	ISO4762
7	5000010883	1	pc	Sechskantmutter Tuerca hexagonal	Hexagon nut Écrou hexagonal		
8	5100005106	1	pc	Vierkantrohr Kpl. Tubo cuadrado cpl.	Square tube cpl. Tube carré cpl.		
9	5000211795	8	pc	Sicherungsschraube Tornillo	Corrugated-head screw Vis		
10	5100005538	1	pc	Faltenbalg Fuelle acordeón	Bellows Soufflet		
11	5000043928	1	pc	Gewindespindel Kpl. Husillo roscado cpl.	Threaded spindle cpl. Tige fileté cpl.		
12	5000202866	1	pc	Sechskantmutter Contratuerca	Locknut Contre-écrou	M16	EN1661
13	5000043233	1	pc	Gummi-Metall-Kerbpuffer Tope caucho-metal	Shockmount Tampon métallique oscillant	60 x 40	
14	5100051255	2	pc	Buchse Buje	Bush Boîte		
15	5100005541	1	pc	Arretierung Dispositivo de retención	Lock Dispositif d'arrêt		
16	5000129818	2	pc	Gummi-Metall-Puffer Tope caucho-metal	Shockmount Tampon métallique oscillant		
17	5000010742	2	pc	Scheibe Arandela	Washer Rondelle		
18	5000011543	2	pc	Zylinderschraube Tornillo hueco	Socket head screw Vis à six-pans creux	M8 x 20 24Nm/18ft.lbs	ISO4762
19	5100010497	4	pc	Gummipuffer Tope caucho-metal	Shockmount Tampon oscillant		
20	5000010882	4	pc	Sechskantmutter Tuerca hexagonal	Hexagon nut Écrou hexagonal		
21	5100005526	1	pc	Flansch Brida	Flange Bride		
22	5000069225	1	pc	Einschraubstutzen Empalme roscado	Screwed socket Manchon visse		
23	5100005553	1	pc	Schlauchleitung Conducto flexible	Hose pipe Conduite flexible		
24	5100027083	1	pc	Deichselkopf Kpl. Cabezal de mando cpl.	Center pole head cpl. Tête de timon cpl.		
25	5000011539	4	pc	Zylinderschraube Tornillo cilíndrico	Cheese head screw Vis à tête cylindrique	M8 x 40 25Nm/18ft.lbs	ISO4762
26	5000215035	2	pc	Gummi-Metall-Puffer Tope caucho-metal	Shockmount Tampon métallique oscillant		
27	5000011527	2	pc	Zylinderschraube Tornillo cilíndrico	Cheese head screw Vis à tête cylindrique		
28	5100005124	1	pc	Bügel Abrazadera	Clamp Attache		

Deichsel Kpl.  
Center pole cpl.  
Barra de mando cpl.  
Timon cpl.

DPU6555HeH

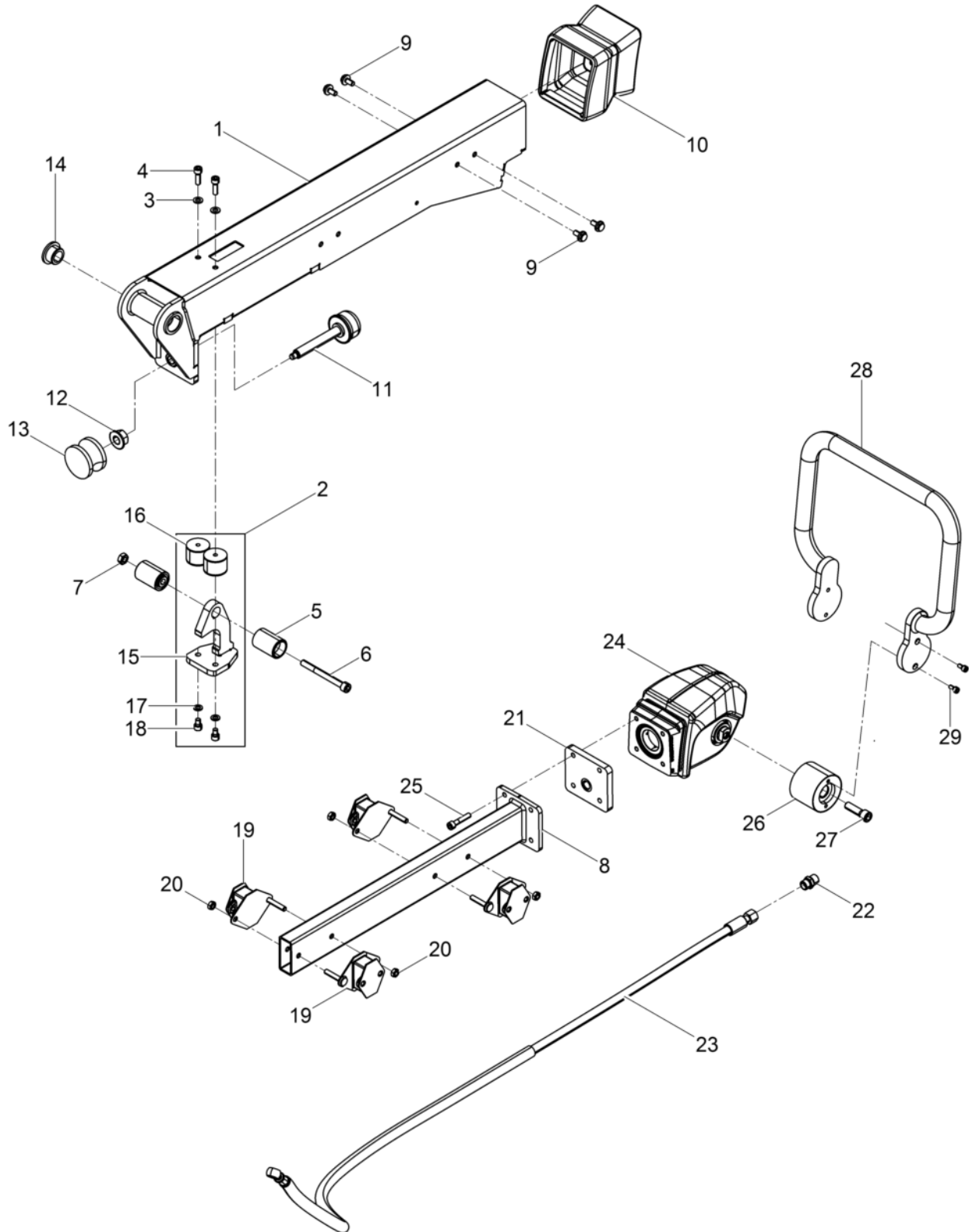

Pos. Item	Artikel Nr. Item no.	Pc.	Unit	Beschreibung Descripción	Description Description	Abm. Dim.	Norm Standard
						Drehmoment Torque	Schmierstoff Lubricant
29	5000011554	4	pc	Zylinderschraube Tornillo cilíndrico	Cheese head screw Vis à tête cylindrique		

Deichselkopf Kpl.  
Center pole head cpl.  
Cabezal de mando cpl.  
Tête de timon cpl.

DPU6555HeH

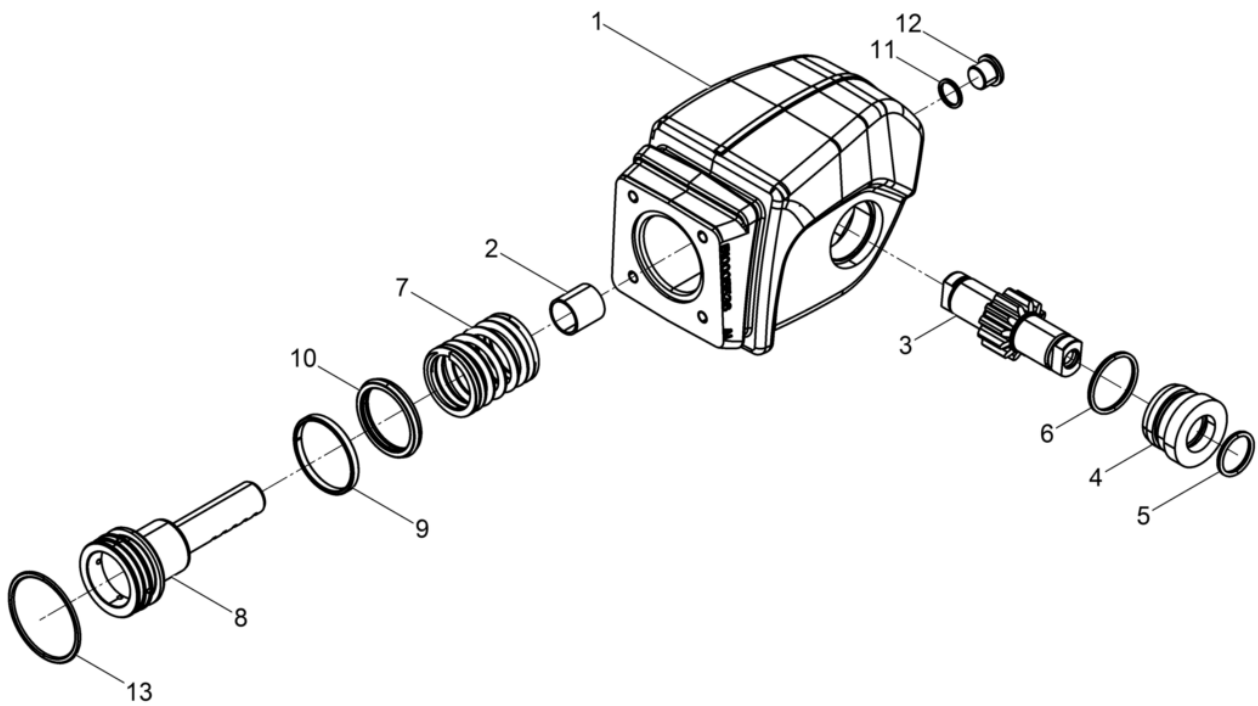

Pos. Item	Artikel Nr. Item no.	Pc.	Unit	Beschreibung Descripción	Description Description	Abm. Dim.	Norm Standard
						Drehmoment Torque	Schmierstoff Lubricant
1	5100005537	1	pc	Deichselkopf Cabezal de barra	Center pole head Tête de timon		
2	5000126164	1	pc	Gleitbuchse Buje deslizante	Slide bush Bôte de glissement		
3	5000069726	1	pc	Zahnradwelle Eje de rueda dentada	Long face pinion Arbre formant pignon		
4	5000125926	2	pc	Distanzstück Pieza distanciadora	Spacer Pièce d'écartement		
5	5000018194	2	pc	O-Ring Anillo-o	O-ring Bague-o		
6	5000068752	2	pc	O-Ring Anillo-o	O-ring Bague-o		
7	5100005559	1	pc	Druckfeder Resorte de compresión	Compression spring Ressort de pression		
8	5100005138	1	pc	Steuerkolben Pistón de mando	Control piston Piston de commande		
9	5100005532	1	pc	Führungsring Anillo guía	Guide ring Bague de guidage	KB 55x50x5,5 HG517	
10	5100005533	1	pc	Dichtung Junta	Gasket Joint		
11	5000012082	1	pc	Dichtungsring Anillo sellador	Seal ring Rondelle à étancher	A16 x 20	DIN7603
12	5000011050	1	pc	Verschlusschraube Tapón roscado	Plug (threaded) Bouchon	M16 x 1,5	DIN908
13	5000039235	1	pc	O-Ring Anillo-o	O-ring Bague-o	58 x 3	

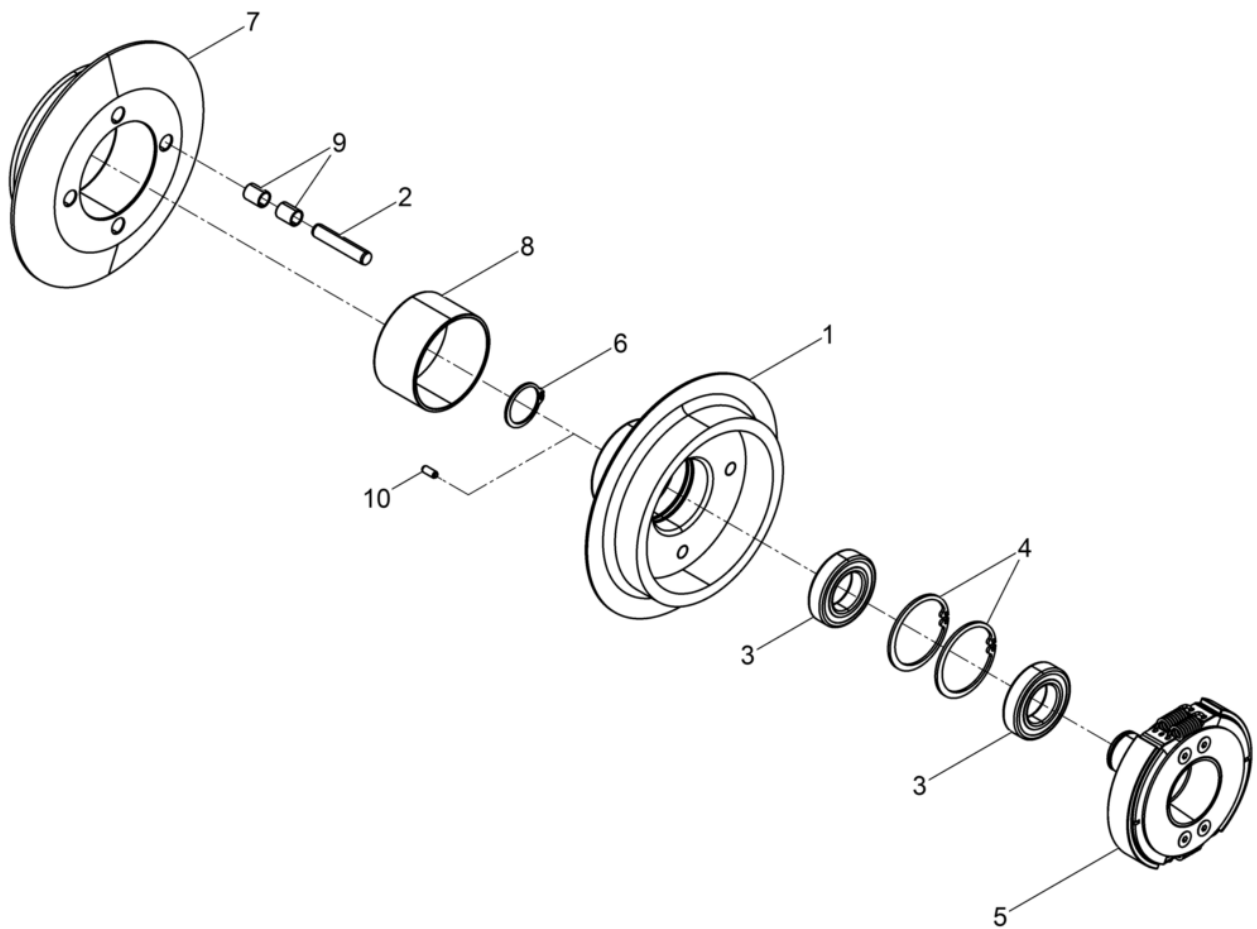

Pos. Item	Artikel Nr. Item no.	Pc.	Unit	Beschreibung Descripción	Description Description	Abm. Dim.	Norm Standard
						Drehmoment Torque	Schmierstoff Lubricant
1	5000058541	1	pc	Kupplungsglocke Campana del embrague	Clutch drum Cloche de rentrée	49Nm/36ft.lbs	
2	5000058539	4	pc	Stift Espiga	Pin Goupille		
3	5000039999	2	pc	Rillenkugellager Rodamiento a bolas	Grooved ball bearing Roulement rainuré à billes		
4	5002003826	2	pc	Sicherungsring Anillo de retención	Retaining ring Bague d'arrêt	55 x 2	DIN472
5	5000201992	1	pc	Fliehkraftkupplung Embrague	Centrifugal clutch Embrayage		
6	5002001815	1	pc	Sicherungsring Anillo de retención	Retaining ring Bague d'arrêt	30 x 1,5	DIN471
7	5000058540	1	pc	Keilriemenscheibe Polea en v	V-belt pulley Poulie à courroie		
8	5000058536	1	pc	Buchse Buje	Bushing Boîte	70 ID	
9	5000058551	8	pc	Buchse Casquillo	Bush Bôte	10 ID	
10	5000013591	2	pc	Spannstift Pasador de sujeción	Spring pin Goupille élastique	5 x 12	DIN1481

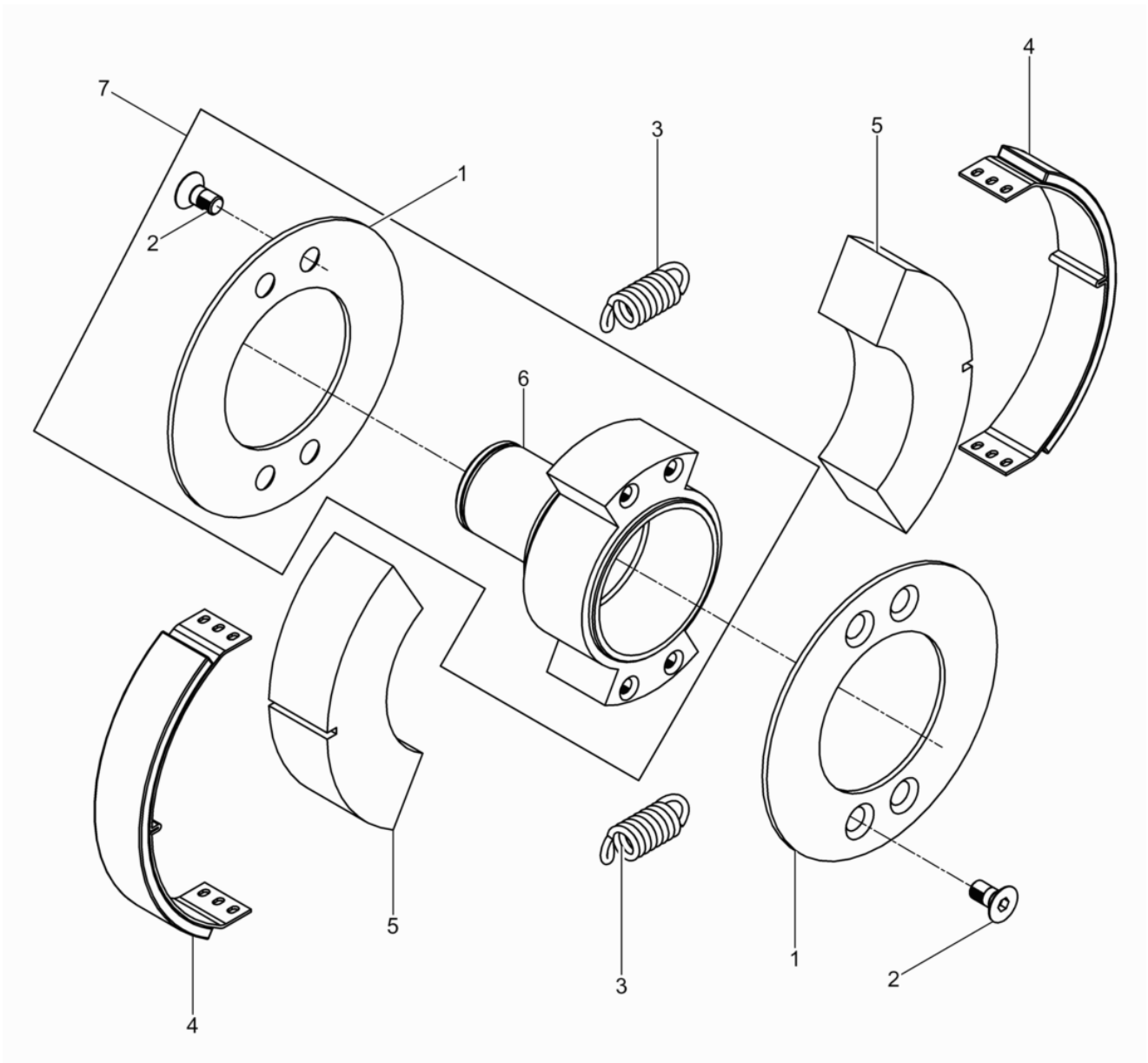

Pos. Item	Artikel Nr. Item no.	Pc.	Unit	Beschreibung Descripción	Description Description	Abm. Dim.	Norm Standard
						Drehmoment Torque	Schmierstoff Lubricant
1	5000201994	2	pc	Fixierscheibe Arandela de retención	Fixing disc Rondelle de fixation		
2	5000024338	8	pc	Senkschraube Tornillo avellanado	Countersunk screw Vis noyée	M6 x 10	DIN963
3	5000045979	4	pc	Zugfeder Resorte de tracción	Tension spring Ressort de traction		
4	5002006075	2	pc	Belagträger Zapata	Lining Garniture d'embrayage		
5	5000049506	2	pc	Fliehgewicht Peso centrifugo	Centrifugal weight Poids centrifuge		
6	5000201993	1	pc	Nabe Cubo	Hub Moyeu		
7	5000203003	1	pc	Nabensatz Juego de cubo	Hub kit Jeu de moyeu		

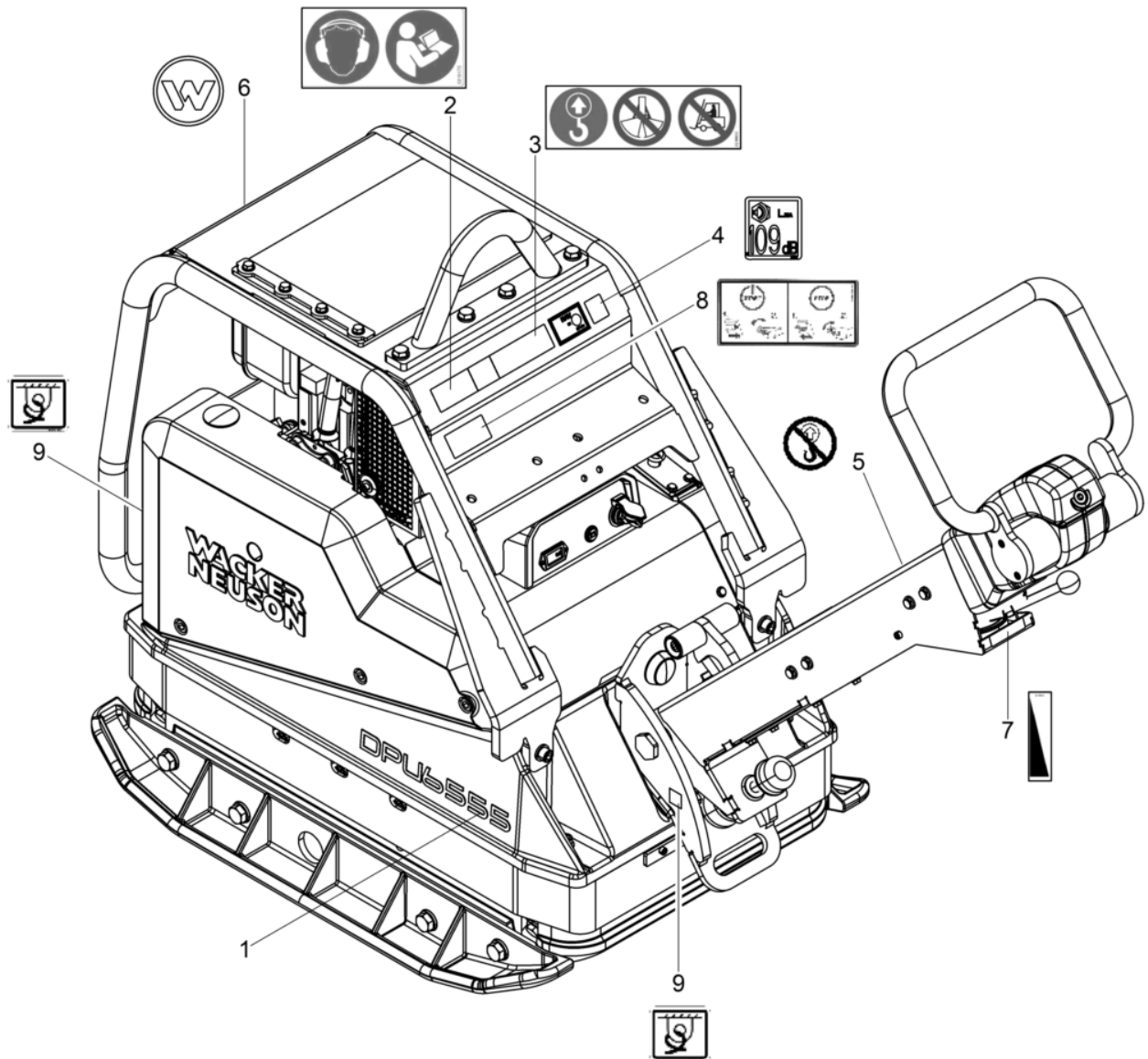

Pos. Item	Artikel Nr. Item no.	Pc.	Unit	Beschreibung Descripción	Description Description	Abm. Dim.	Norm Standard
						Drehmoment Torque	Schmierstoff Lubricant
1	5000220386	2	pc	Aufkleber-Typ Tipo etiqueta autoadhesiva	Type label Autocollant de type		
2	5000219175	1	pc	Aufkleber Calcomanías	Labels Autocollants		
3	5000216633	1	pc	Aufkleber-Hinweis Calcomanía-indicación	Instruction label Autocollant avec indication		
4	5000064925	1	pc	Aufkleber-Schalleistungspegel Etiqueta autoadhesiva-nivel de potencia acúëstica	Decal-sound power level Autocollante-niveau sonore		
5	5000220000	1	pc	Aufkleber-Warnhinweis Calcomanía-indicación	Instruction label Autocollant avec indication		
6	5000222085	1	pc	Aufkleber Symbol Calcomanía símbolo	Label symbol Autocollant symbole		
7	5000219259	1	pc	Aufkleber Calcomanías	Labels Autocollants		
8	5100026807	1	pc	Aufkleber (Start Stop) Calcomanías (start stop)	Labels (start stop) Autocollants (start stop)		
9	1000184310	3	pc	Aufkleber Calcomanía	Label Autocollant		

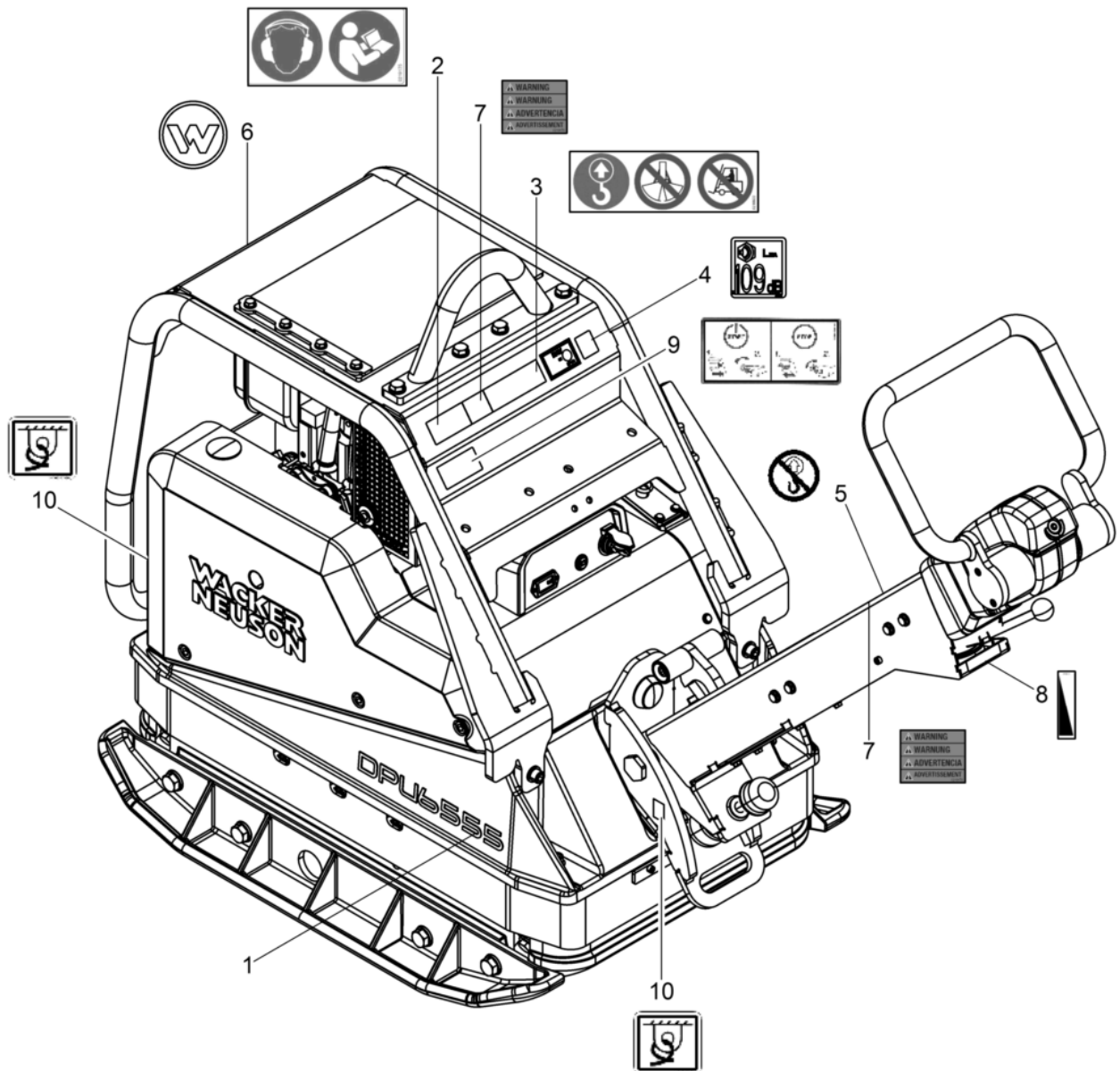

Pos. Item	Artikel Nr. Item no.	Pc.	Unit	Beschreibung Descripción	Description Description	Abm. Dim.	Norm Standard
						Drehmoment Torque	Schmierstoff Lubricant
1	5000220386	2	pc	Aufkleber-Typ Tipo etiqueta autoadhesiva	Type label Autocollant de type		
2	5000219175	1	pc	Aufkleber Calcomanías	Labels Autocollants		
3	5000216633	1	pc	Aufkleber-Hinweis Calcomanía-indicación	Instruction label Autocollant avec indication		
4	5000064925	1	pc	Aufkleber-Schalleistungspegel Etiqueta autoadhesiva-nivel de potencia acúëstica	Decal-sound power level Autocollante-niveau sonore		
5	5000220000	1	pc	Aufkleber-Warnhinweis Calcomanía-indicación	Instruction label Autocollant avec indication		
6	5000222085	1	pc	Aufkleber Symbol Calcomanía símbolo	Label symbol Autocollant symbole		
7	5000219176	2	pc	Aufkleber Calcomanías	Labels Autocollants		
8	5000219259	1	pc	Aufkleber Calcomanías	Labels Autocollants		
9	5100026807	1	pc	Aufkleber (Start Stop) Calcomanías (start stop)	Labels (start stop) Autocollants (start stop)		
10	1000184310	3	pc	Aufkleber Calcomanía	Label Autocollant		

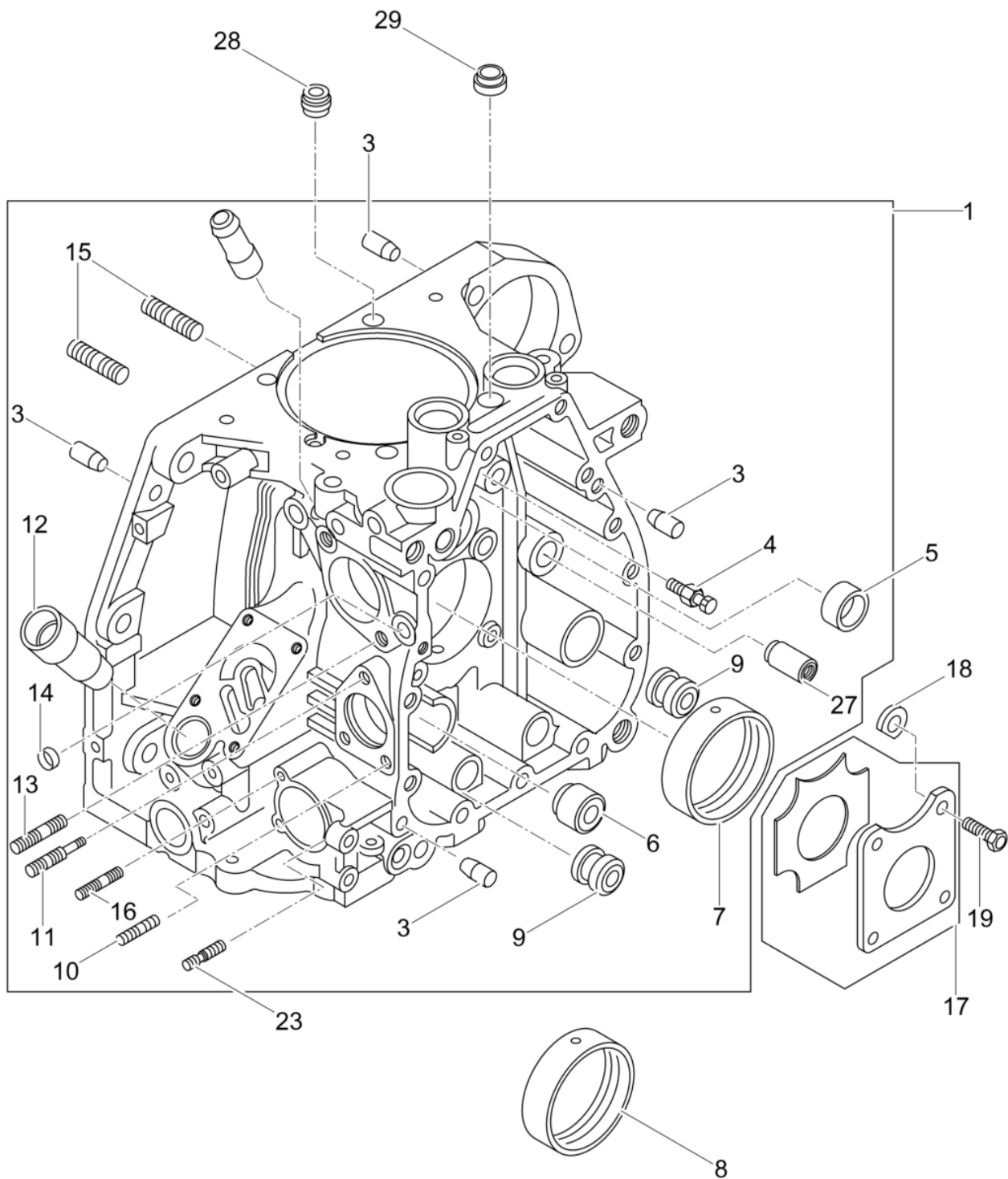

Pos. Item	Artikel Nr. Item no.	Pc.	Unit	Beschreibung Descripción	Description Description	Abm. Dim.	Norm Standard
						Drehmoment Torque	Schmierstoff Lubricant
1	5000126516	1	pc	Kurbelgehäuse Cárter	Crankcase Carter manivelle		
3	5000108694	4	pc	Zylinderstift Pasador cilíndrico	Straight pin Goupille cylindrique	8m6 x 20	DIN6325
4	5000094922	1	pc	Schmiereinrichtung Dispositivo de lubricación	Lubrication jet Dispositif de lubrification		
5	5000226589	1	pc	Lagerbuchse Casquillo del cojinete	Bearing bush Bôte de roulement		
6	5000207596	1	pc	Stopfen Tapón	Push-in plug Bouchon		
7	5000094924	1	pc	Gleitlager Rodamiento	Bearing Roulement		
8	5000107228	1	pc	Gleitlager Cojinete deslizante	Slide bearing Roulement de glissement	-0,5	
9	5000207597	1	pc	Stopfen Tapón	Push-in plug Bouchon		
10	5000202433	2	pc	Gewindebolzen Perno roscado	Threaded bolt Boulon fileté	M6 x 16	
11	5000094925	1	pc	Stiftschraube Perno prisionero	Stud bolt Boulon		
12	5100046078	1	pc	Einfüllstutzen Tubo llenador de aceite	Oil fill tube Tube-remplisseur d'huile		
13	5000226600	2	pc	Stiftschraube Perno prisionero	Stud Boulon	M8x25	
14	5000202447	1	pc	Scheibe Arandela	Washer Rondelle	A3C	
15	5100013800	8	pc	Stiftschraube Perno prisionero	Stud Boulon	M8x22	
16	5000099414	2	pc	Stiftschraube Perno prisionero	Stud Boulon	M6 x 22	
17	5100030356	1	pc	Anlaufscheibe Kpl. Arandela tope cpl.	Check disc cpl. Disque cpl.		
18	5000098454	1	pc	Scheibe Arandela	Washer Rondelle	1,2	
18	5000098455	1	pc	Scheibe Arandela	Washer Rondelle	1,05	
19	5000098456	4	pc	Sechskantschraube Tornillo hexagonal	Hexagonal head cap screw Vis à tête hexagonale		
23	5000099414	1	pc	Stiftschraube Perno prisionero	Stud Boulon	M6 x 22	
27	5000202406	1	pc	Buchse Buje	Bush Boîte		
28	5100051909	2	pc	Dichtung Junta	Gasket Joint		
29	5000097403	2	pc	Gummitülle Ojal	Grommet Passe-fil		

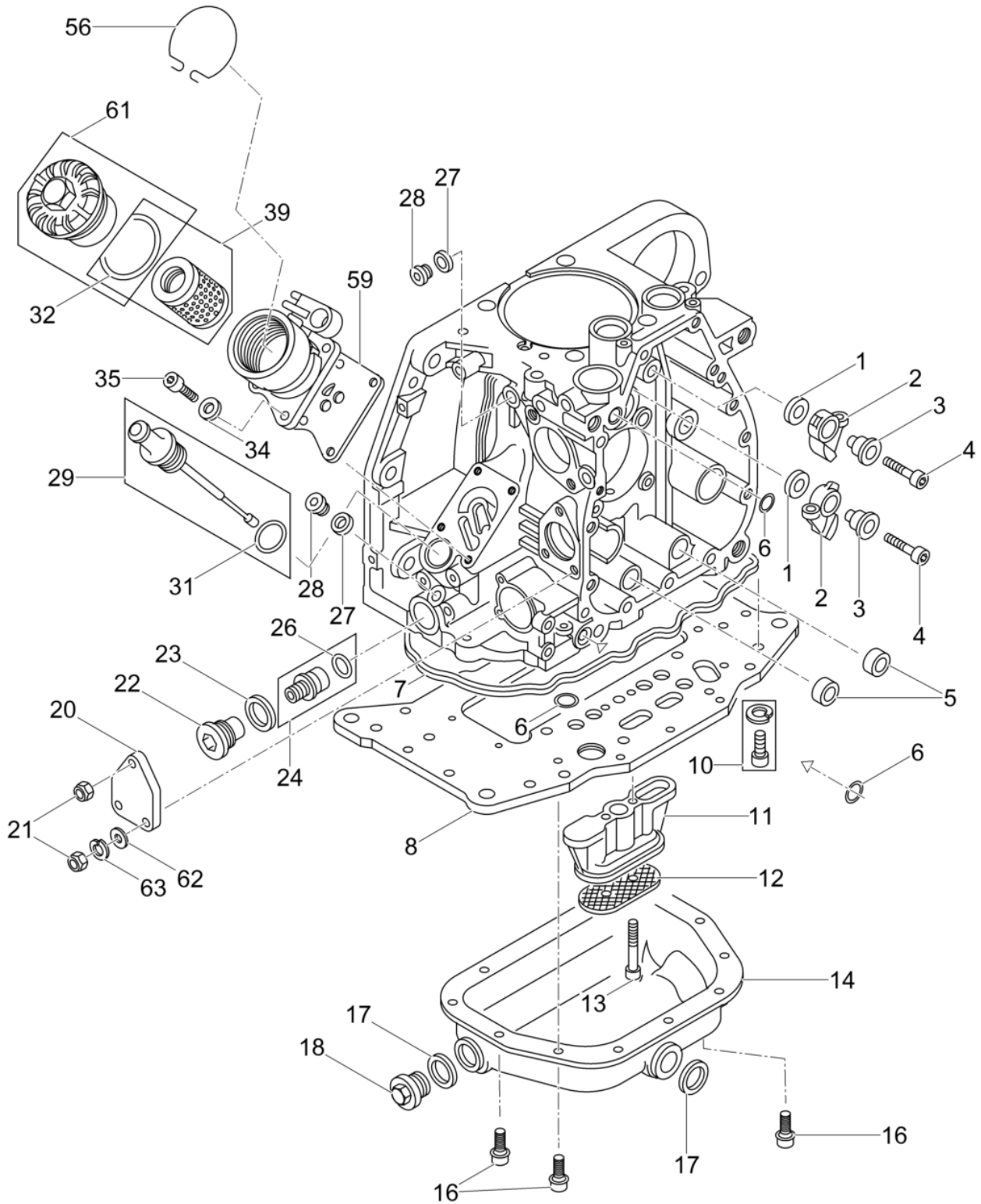

Pos. Item	Artikel Nr. Item no.	Pc.	Unit	Beschreibung Descripción	Description Description	Abm. Dim.	Norm Standard
						Drehmoment Torque	Schmierstoff Lubricant
1	5000104365	2	pc	Scheibe Arandela	Washer Rondelle	10.1 x 22 x 3	
2	5000094937	2	pc	Schlepphebel Palanca deslizante	Sliding lever Levier glissant		
3	5000094936	2	pc	Buchse Rodillo de leva	Cam follower spindle shaft Contre-came		
4	5000217112	2	pc	Zylinderschraube Tornillo cilíndrico	Cheese head screw Vis à tête cylindrique	M6 x 30	
5	5000094935	2	pc	Flachdichtring Arandela	Washer Rondelle		
6	5000094934	3	pc	O-Ring Anillo-o	O-ring Joint torique	9,5 x 2,5	
7	5000094952	1	pc	Dichtung Junta	Gasket Joint		
8	5000094953	1	pc	Platte Placa	Plate Plaque		
10	5000202463	22	pc	Innensechskantschraube Tornillo a seis lados huecos	Hexagon socket head screw Vis à six pans creux	M8 x 25	
11	5000094954	1	pc	Sauggehäuse Caja	Housing Carter		
12	5000094955	1	pc	Sieb Tamizador	Strainer Tamis		
13	5000094956	2	pc	Zylinderschraube Tornillo cilíndrico	Cheese head screw Vis à tête cylindrique	M6 x 50 10Nm/7ft.lbs	DIN6912
14	5000094957	1	pc	Ölwanne Tapa	Cover Couvercle		
16	5100051919	12	pc	Gewindestift Varilla roscada	Threaded pin Goupille fileté		
17	5000202416	2	pc	Öldichtung Junta de aceite	Oil seal Joint d'huile	52 x 80 x 10	
18	5000094958	1	pc	Verschlusschraube Tapón roscado	Plug (threaded) Bouchon	AM22 x 1,5	DIN7604
20	5000207539	1	pc	Deckel Tapa	Cover Couvercle		
21	5000129021	3	pc	Sechskantmutter Contratuerca	Locknut Contre-écrou	VM6	
22	5000126921	1	pc	Verschlusschraube Tornillo de cierre	Screw plug Vis de fermeture		
23	5000094948	1	pc	Dichtring Anillo de junta	Gasket Bague d'étanchéité	A24 x 29	DIN7603
24	5000106530	1	pc	Ventil Válvula	Valve Soupape		
26	5000126922	1	pc	O-Ring Anillo-o	O-ring Bague-o	18 x 2	
27	5000071121	2	pc	Dichtungsring Anillo sellante	Sealing ring Bague d'étanchéité	A10 x 13,5	
28	5000151213	2	pc	Verschlusschraube Tornillo de cierre	Screw plug Vis de fermeture	M10 X 1	DIN908
29	5100046077	1	pc	Ölpeilstab Varilla indicadora	Oil dip stick Jauge d'huile		
31	5000151217	1	pc	Wellendichtring Anillo de sellado	Gasket Anneau d'étanchéité	26x35x3	
32	5000094928	1	pc	Flachdichtring Juntaaceite	Gasket Joint		
34	5000151290	4	pc	Federscheibe Arandela elástica	Spring washer Rondelle à ressort	A6	DIN137

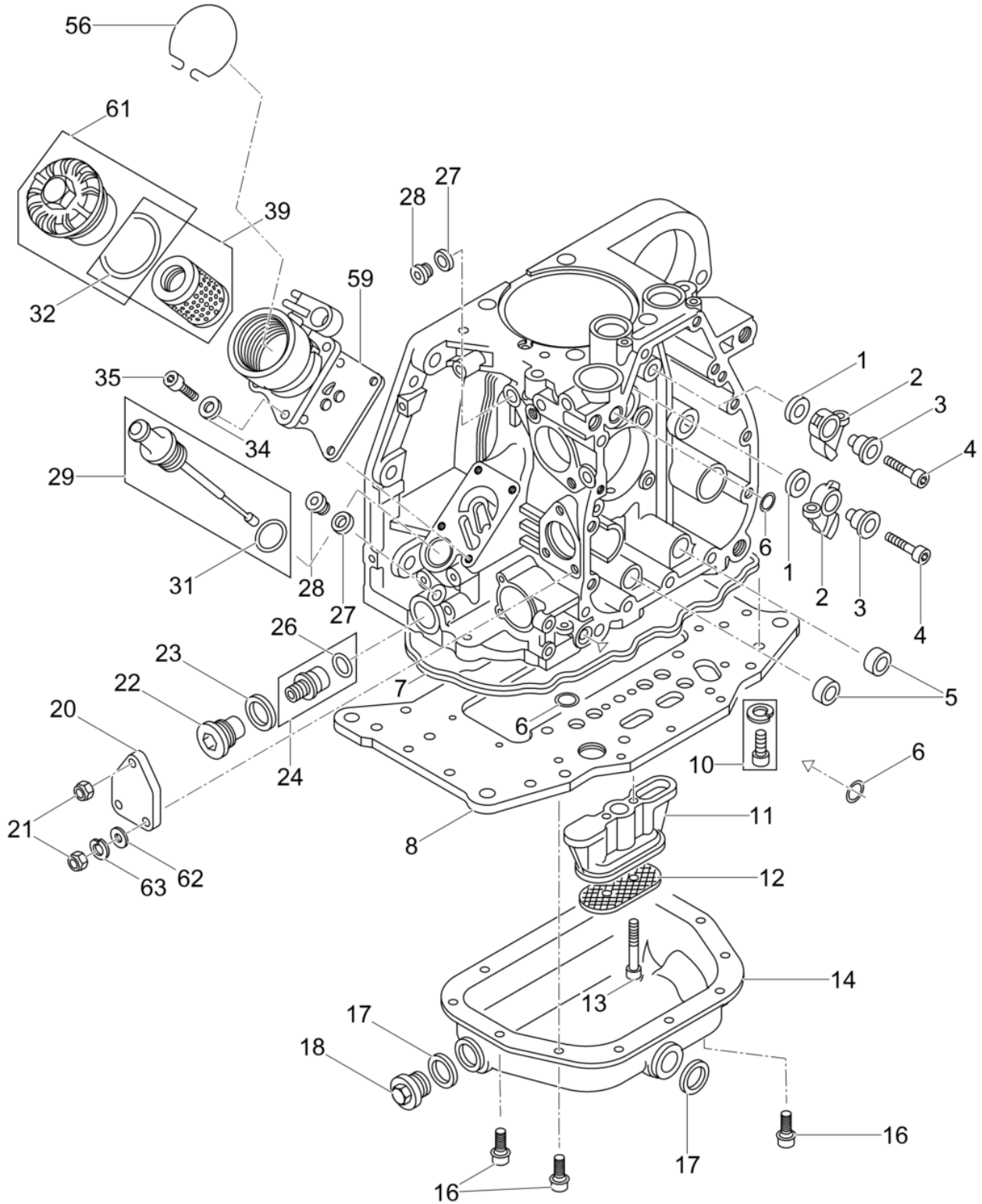

Pos. Item	Artikel Nr. Item no.	Pc.	Unit	Beschreibung Descripción	Description Description	Abm. Dim.	Norm Standard
						Drehmoment Torque	Schmierstoff Lubricant
35	5000202437	4	pc	Zylinderschraube Tornillo cilíndrico	Cheese head screw Vis à tête cylindrique	M6 x 20	
39	5100051956	1	pc	Ölfilter Filtro de aceite	Oil filter Filtre d'huile		
56	5000104402	1	pc	Drahtfeder Resorte	Spring Ressort		
59	5000106559	1	pc	Dichtung Junta	Seal Joint		
61	5000094931	1	pc	Schraubdeckel Tapa	Cover Couvercle		
62	5000151324	2	pc	Scheibe Arandela	Washer Rondelle	6.4	
63	5000151456	2	pc	Federring Arandela elástica	Lock washer Rondelle de ressort	6	DIN128

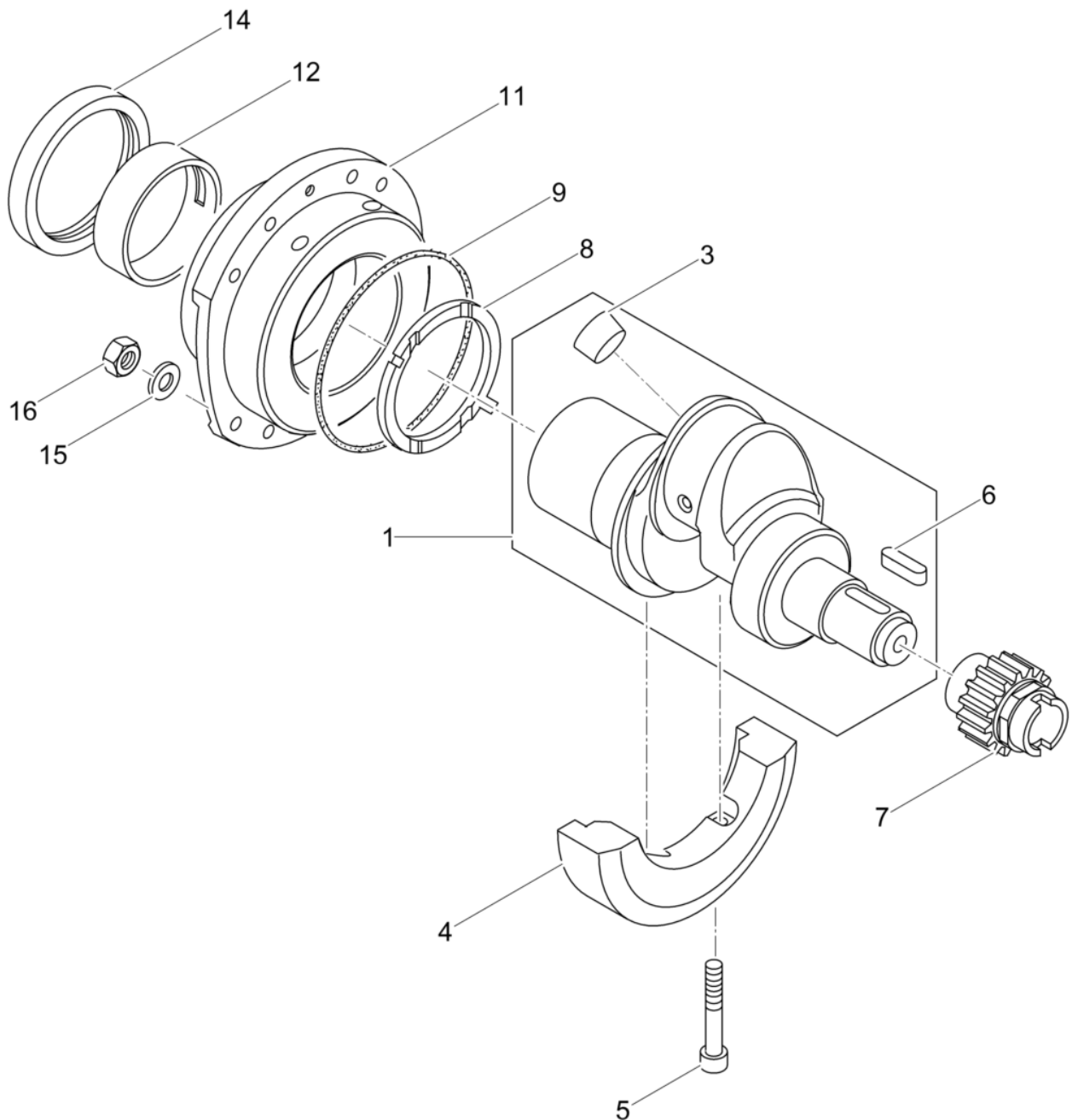

Pos. Item	Artikel Nr. Item no.	Pc.	Unit	Beschreibung Descripción	Description Description	Abm. Dim.	Norm Standard
						Drehmoment Torque	Schmierstoff Lubricant
1	5100030358	1	pc	Kurbelwelle Cigüeñal	Crankshaft Vilebrequin		
3	5000207600	1	pc	Deckel Tapa	Cover Couvercle		
4	5000094870	1	pc	Gegengewicht Contrapeso	Counterweight Contrepoids		
5	5000217110	2	pc	Zylinderschraube Tornillo cilíndrico	Cheese head screw Vis à tête cylindrique	M10 x 50	
6	5000094868	1	pc	Passfeder Chaveta	Fitting key Clavette	A6 x 4 x 32	DIN6885
7	5000106529	1	pc	Ritzel Piñón	Pinion Pignon		
8	5000094871	1	pc	Schleuderblech Placa	Plate Plaque		
9	5000094872	1	pc	O-Ring Anillo-o	O-ring Joint torique		
11	5000128939	1	pc	Lagerflansch Brida-rodamiento	Bearing flange Collette-roulement		
12	5000094874	1	pc	Gleitlager Rodamiento	Bearing Roulement		
12	5000107223	1	pc	Gleitlager Cojinete deslizante	Slide bearing Roulement de glissement	-0,5	
14	5000094875	1	pc	Wellendichtring Sello del eje	Shaft seal Bague d'étanchéité		
15	5000202460	8	pc	Scheibe Arandela	Washer Rondelle	8,4	
16	5000094876	8	pc	Sechskantmutter Tuerca hexagonal	Hexagon nut Écrou hexagonal	M8	ISO4032

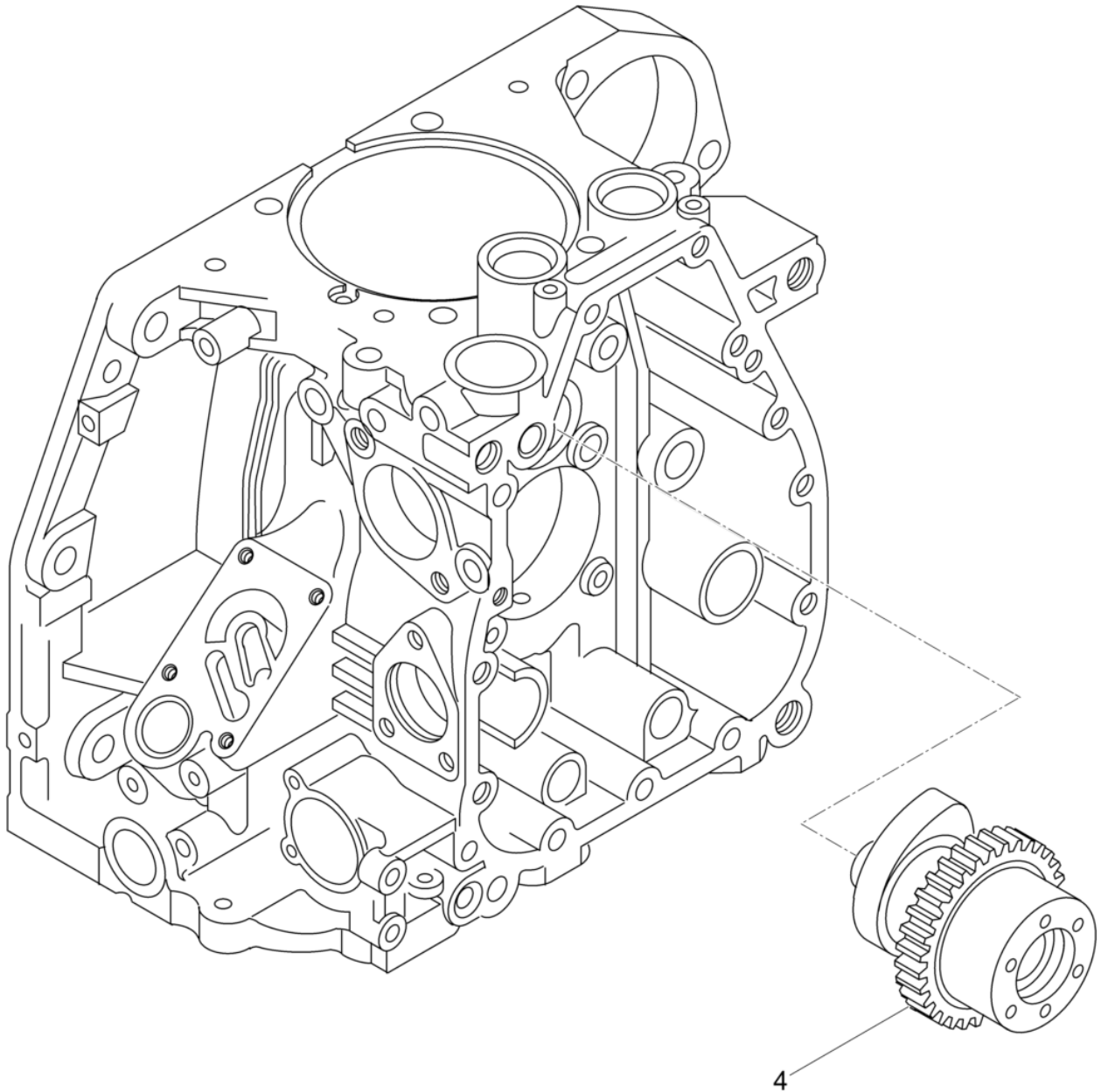

Pos. Item	Artikel Nr. Item no.	Pc.	Unit	Beschreibung Descripción	Description Description	Abm. Dim.	Norm Standard
						Drehmoment Torque	Schmierstoff Lubricant
4	5000207584	1	pc	Nockenwelle Arbol de levas	Camshaft Arbre à cames		

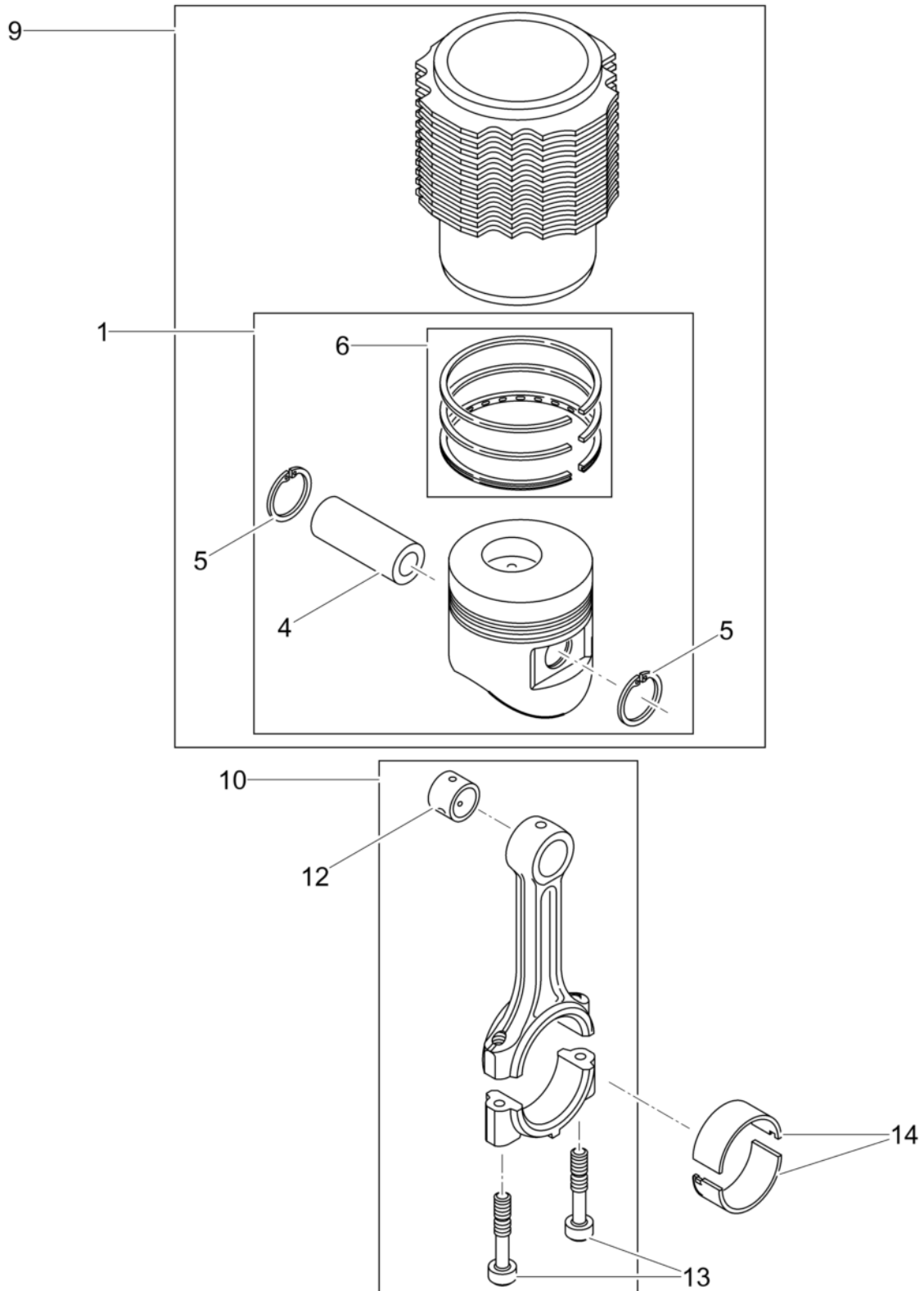

Pos. Item	Artikel Nr. Item no.	Pc.	Unit	Beschreibung Descripción	Description Description	Abm. Dim.	Norm Standard
						Drehmoment Torque	Schmierstoff Lubricant
1	5000217087	1	pc	Kolben Pistón	Piston Piston		
4	5000094862	1	pc	Kolbenbolzen Pasador de pistón	Piston pin Axe de piston		
5	5100051908	2	pc	Sicherungsring Anillo de retención	Retaining ring Bague d'arrêt		
6	5000217086	1	pc	Kolbenringsatz Juego de anillos	Set-piston rings Jeu de segments		
9	5000217089	1	pc	Zylinder Mit Kolben Cilindro con pistón	Cylinder with piston Cylindre avec piston		
10	5100051962	1	pc	Pleuelstange Kpl. Biela cpl.	Connecting rod cpl. Bielle cpl.		
12	5000094864	1	pc	Pleuelbuchse Buje	Bushing Douille		
13	5000105927	2	pc	Pleuelschraube Tornillo de la biela	Connecting rod screw Vis de bielle		
14	5000094866	1	pc	Pleuellager Rodamiento	Bearing Roulement		
14	5000107222	1	pc	Pleuellager Cojinete de la biela	Connecting rod bearing Coussinet de bielle	-0,5	

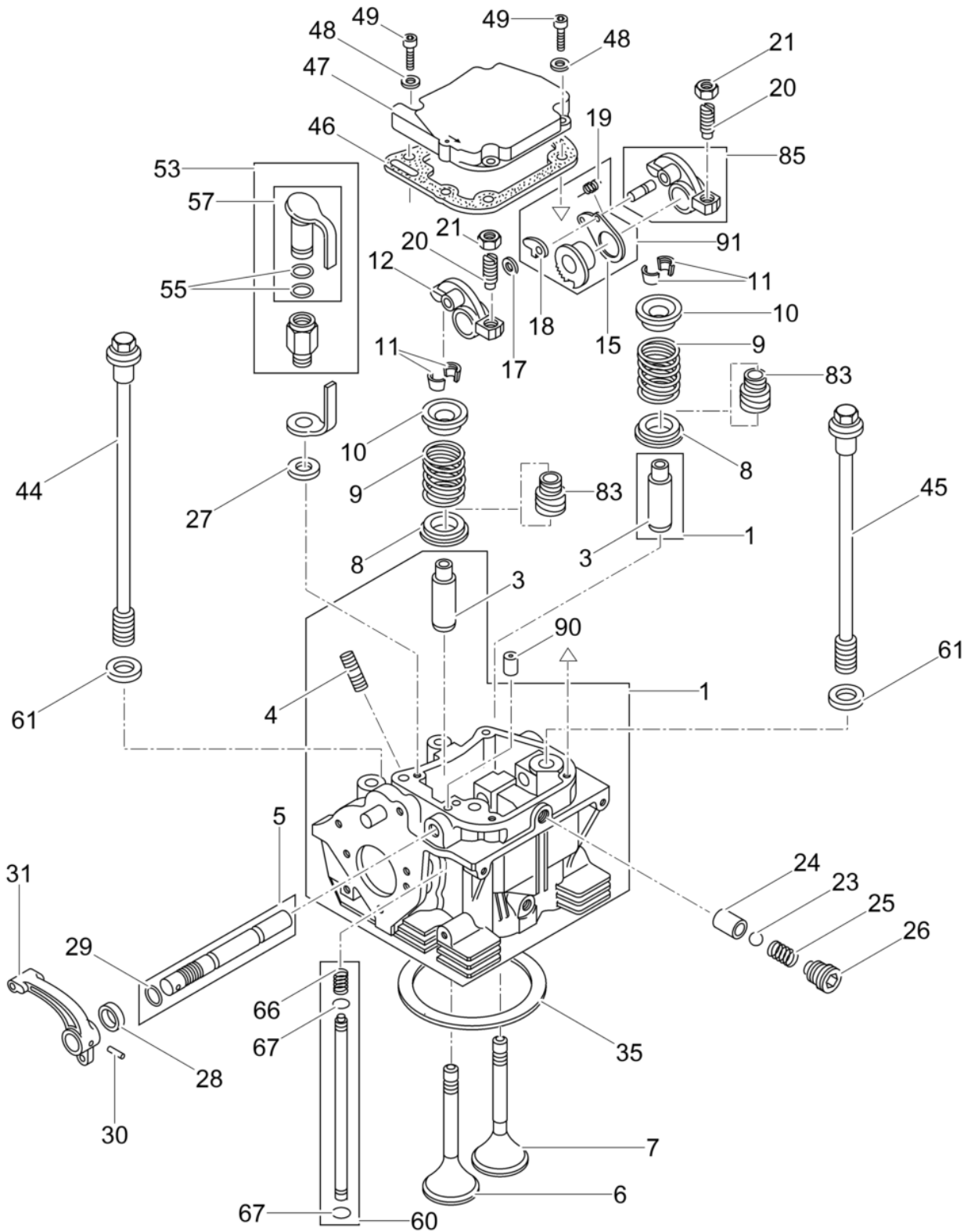

Pos. Item	Artikel Nr. Item no.	Pc.	Unit	Beschreibung Descripción	Description Description	Abm. Dim.	Norm Standard
						Drehmoment Torque	Schmierstoff Lubricant
1	5000126515	1	pc	Zylinderkopf Culata	Cylinder head Culasse		
3	5000094890	2	pc	Ventilführung Guíaválvula	Valve guide Guide de soupape		
4	5000207595	1	pc	Stiftschraube Perno prisionero	Stud Boulon	M8 x 35	
5	5000105928	1	pc	Kipphebelachse Eje de la balancín	Rocker shaft Axe de culbuteur		
6	5000105043	1	pc	Einlassventil Válvula de admisión	Intake valve Soupape d'admission		
7	5000105044	1	pc	Auslaßventil Válvula de escape	Exhaust valve Soupape d'échappement		
8	5000094902	2	pc	Scheibe Arandela	Washer Rondelle		
9	5000094901	2	pc	Ventilfeder Resorte	Spring Ressort		
10	5100051933	2	pc	Federteller Platillo de resorte	Spring holder Cuvette à ressort		
11	5000094899	2	pc	Ventilkonussatz Juego-cono de válvula	Set-taper cone valve Jeu-cone de soupape		
12	5000098449	1	pc	Einlaßkipphebel Balancín de admisión	Inlet rocker arm Culbuteur		
15	5000094895	1	pc	Halter Soporte	Holder Attache		
17	5000202427	1	pc	Sicherungscheibe Arandela de seguridad	Lock washer Rondelle d'arrêt		
18	5000094897	1	pc	Mitnehmer Trinquete	Ratchet (pawl) Cliquet		
19	5000094894	1	pc	Feder Resorte	Spring Ressort		
20	5000094891	2	pc	Einstellschraube Tornillo de ajuste	Adjustment screw Vis d'ajustage		
21	5004101500	2	pc	Sechskantmutter Contratuerca	Locknut Contre-écrou	5/16 x 24in	
23	5000066801	1	pc	Kugel Bola	Ball Bille		
24	5100032122	1	pc	Buchse Buje	Bush Boîte		
25	5000094887	1	pc	Feder Resorte	Spring Ressort		
26	5000094888	1	pc	Schraube Tornillo	Screw Vis		
27	5000013186	1	pc	Dichtring Anillo de junta	Gasket Bague d'étanchéité	A12 x 15,5	DIN7603
28	5000097401	1	pc	Dichtscheibe Empaque	Seal Joint		
29	5000108801	1	pc	O-Ring Anillo-o	O-ring Bague-o	8 x 2	
30	5000020183	1	pc	Spannstift Pasador de sujeción	Spring pin Goupille élastique	4 x 22	DIN1481
31	5000094909	1	pc	Hebel Palanca de descompresión	Decompression lever Manette de decompression		
35	5000207552	1	pc	Zylinderkopfdichtung Junta de culata del cilindro	Cylinder head gasket Joint de culasse de cylindre	1,25	
35	5000207551	1	pc	Zylinderkopfdichtung Junta de culata del cilindro	Cylinder head gasket Joint de culasse de cylindre	1,15	

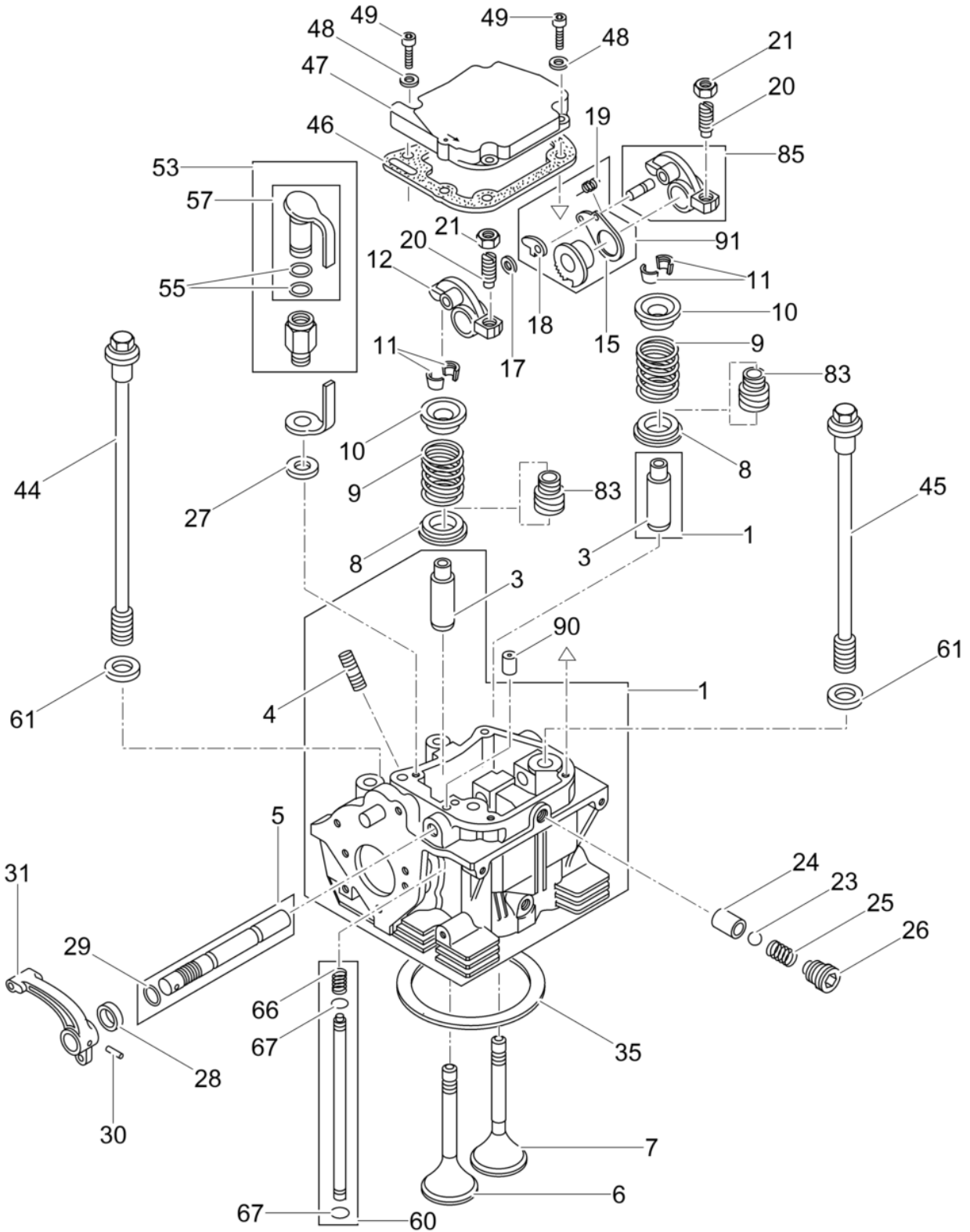

Pos. Item	Artikel Nr. Item no.	Pc.	Unit	Beschreibung Descripción	Description Description	Abm. Dim.	Norm Standard
						Drehmoment Torque	Schmierstoff Lubricant
35	5000207550	1	pc	Zylinderkopfdichtung Junta de culata del cilindro	Cylinder head gasket Joint de culasse de cylindre	1,05	
35	5000207549	1	pc	Zylinderkopfdichtung Junta de culata del cilindro	Cylinder head gasket Joint de culasse de cylindre	0,95	
35	5000207548	1	pc	Zylinderkopfdichtung Junta de culata del cilindro	Cylinder head gasket Joint de culasse de cylindre	0,85	
35	5000207547	1	pc	Zylinderkopfdichtung Junta de culata del cilindro	Cylinder head gasket Joint de culasse de cylindre	0,75	
35	5000207546	1	pc	Zylinderkopfdichtung Junta de culata del cilindro	Cylinder head gasket Joint de culasse de cylindre	0,65	
35	5000207545	1	pc	Zylinderkopfdichtung Junta de culata del cilindro	Cylinder head gasket Joint de culasse de cylindre	0,55	
35	5000099413	1	pc	Zylinderkopfdichtung Junta de culata del cilindro	Cylinder head gasket Joint de culasse de cylindre	0,5	
35	5000094920	1	pc	Zylinderkopfdichtung Junta de culata del cilindro	Cylinder head gasket Joint de culasse de cylindre	1,3	
35	5000094919	1	pc	Zylinderkopfdichtung Junta de culata del cilindro	Cylinder head gasket Joint de culasse de cylindre	1,2	
35	5000094918	1	pc	Zylinderkopfdichtung Junta de culata del cilindro	Cylinder head gasket Joint de culasse de cylindre	1,1	
35	5000094917	1	pc	Zylinderkopfdichtung Junta de culata del cilindro	Cylinder head gasket Joint de culasse de cylindre	1,0	
35	5000094916	1	pc	Zylinderkopfdichtung Junta de culata del cilindro	Cylinder head gasket Joint de culasse de cylindre	0,9	
35	5000094915	1	pc	Zylinderkopfdichtung Junta de culata del cilindro	Cylinder head gasket Joint de culasse de cylindre	0,8	
35	5000094914	1	pc	Zylinderkopfdichtung Junta de culata del cilindro	Cylinder head gasket Joint de culasse de cylindre	0,7	
35	5000094913	1	pc	Zylinderkopfdichtung Junta de culata del cilindro	Cylinder head gasket Joint de culasse de cylindre	0,6	
44	5100030359	2	pc	Sechskantschraube Tornillo hexagonal	Hexagonal head cap screw Vis à tête hexagonale		
45	5000094882	2	pc	Zylinderkopfschraube Tornillo	Screw Vis		
46	5100051932	1	pc	Dichtung Junta	Gasket Joint		
47	5000098444	1	pc	Deckel Tapa	Cover Couvercle		
48	5000151290	4	pc	Federscheibe Arandela elástica	Spring washer Rondelle à ressort	A6	DIN137
49	5000129010	4	pc	Zylinderschraube Tornillo cilíndrico	Cheese head screw Vis à tête cylindrique	M6 x 25	DIN912
53	5000102468	1	pc	Dosiereinrichtung Imprimador	Fuel primer Dispositif d'injection au		
55	5000107390	2	pc	O-Ring Anillo-o	O-ring Joint torique	11,3 x 2,4	
57	5000102469	1	pc	Verschlussstopfen Tapón roscado	Plug (threaded) Bouchon		
60	5000094906	1	pc	Schmierrohr Tubo de grasa	Grease tube Tube de graisse		
61	5000104388	4	pc	Scheibe Arandela	Washer Rondelle	2,5	
66	5000094903	1	pc	Feder Resorte	Spring Ressort		
67	5000094905	2	pc	O-Ring Anillo-o	O-ring Joint torique		

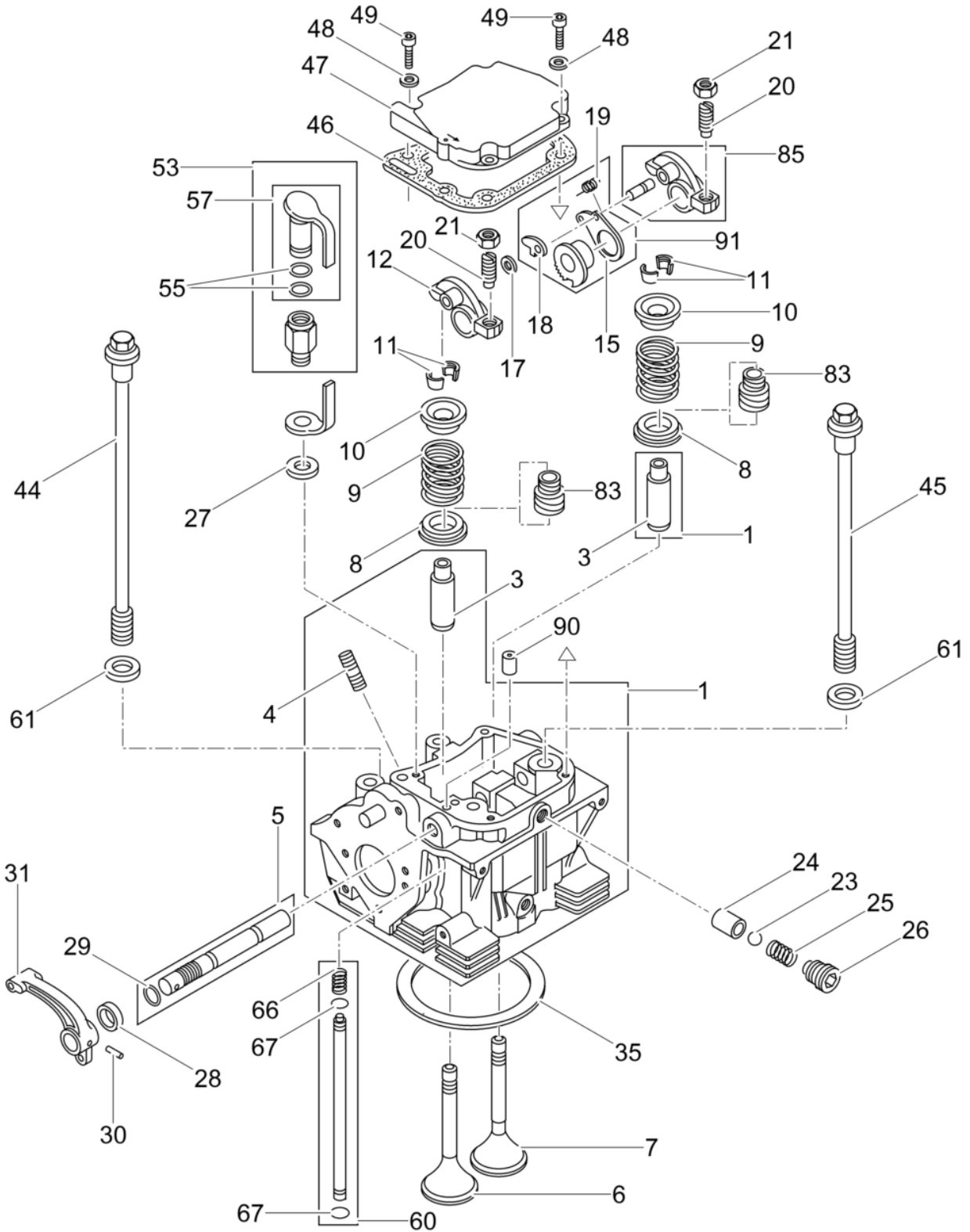

Pos. Item	Artikel Nr. Item no.	Pc.	Unit	Beschreibung Descripción	Description Description	Abm. Dim.	Norm Standard
						Drehmoment Torque	Schmierstoff Lubricant
83	5100010410	2	pc	Abdichtung Junta	Seal Joint		
85	5000098448	1	pc	Auslaßkipphebel Balancín de escape	Exhaust rocker arm Culbuteur		
90	5000207538	1	pc	Düse Gicleur	Jet Gicleur		
91	5000126917	1	pc	Zahnsegment Kpl. Segmento dentado cpl.	Toothed segment cpl. Secteur dentée cpl.		

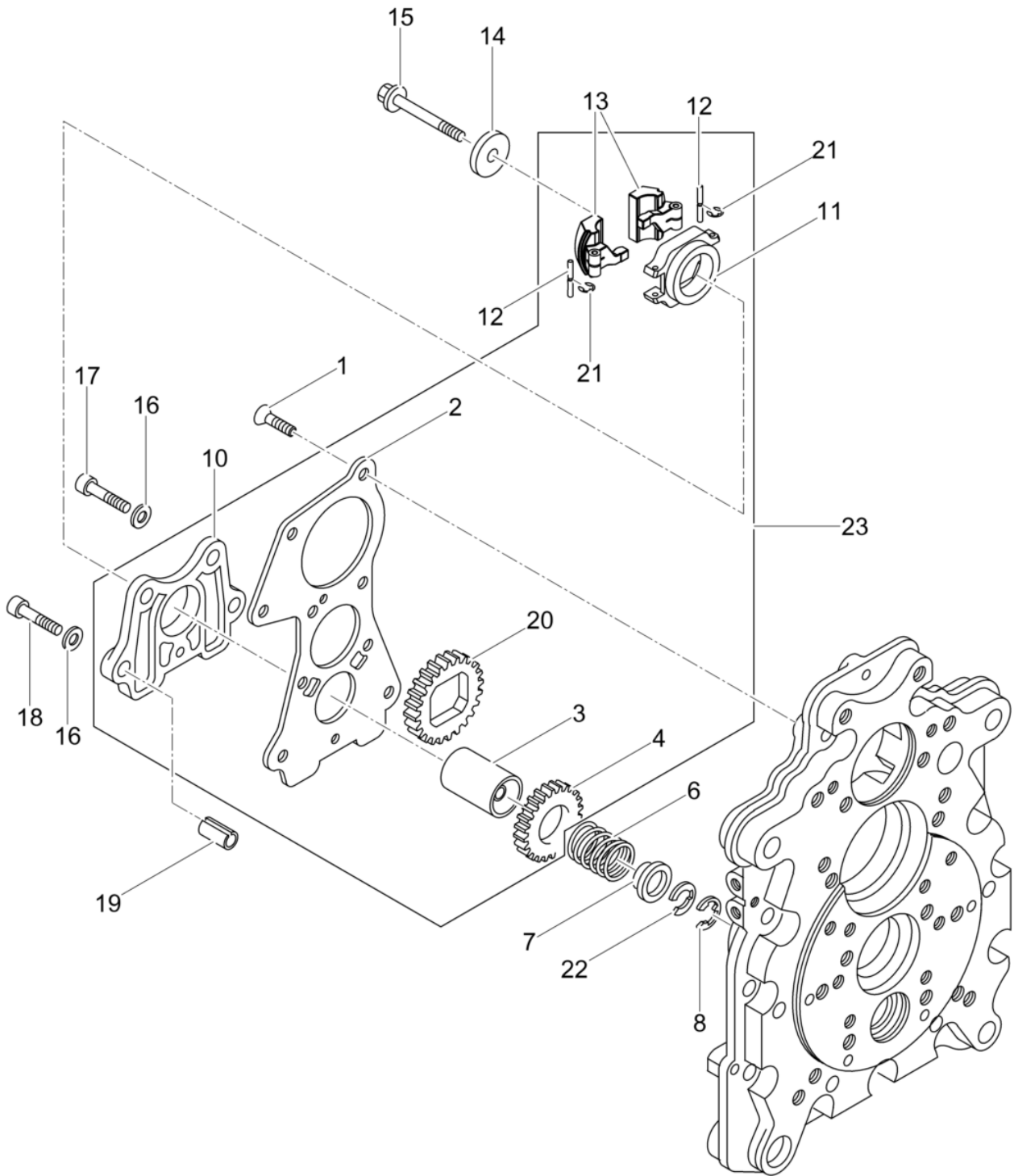

Pos. Item	Artikel Nr. Item no.	Pc.	Unit	Beschreibung Descripción	Description Description	Abm. Dim.	Norm Standard
						Drehmoment Torque	Schmierstoff Lubricant
1	5000095000	5	pc	Senkschraube Tornillo	Screw Vis		
2	5000094999	1	pc	Flanschdeckel Tapa	Cover Couvercle		
3	5000095002	1	pc	Lagerbuchse Buje	Bushing Douille		
4	5000106532	1	pc	Zahnrad Engranaje	Gear wheel Roue dentée		
6	5000095004	1	pc	Feder Resorte	Spring Ressort		
7	5000095005	1	pc	Federteller Soporte	Spring holder Support		
8	5002004956	1	pc	Sicherungsscheibe Arandela de seguridad	Lock washer Rondelle d'arrêt	5	DIN6799
10	5000217097	1	pc	Gehäuse Carcasa	Housing Enveloppe		
11	5100002769	1	pc	Träger Soporte	Bracket Support		
12	5100002771	1	pc	Bolzen Perno	Bolt Boulon		
13	5100002770	1	pc	Fliehkörper Peso centrífugo	Eccentric weight Poids centrifuge		
14	5000094991	1	pc	Scheibe Arandela	Washer Rondelle		
15	5000094990	1	pc	Bolzen Perno	Bolt Boulon		
16	5000151290	5	pc	Federscheibe Arandela elástica	Spring washer Rondelle à ressort	A6	DIN137
17	5000129010	3	pc	Zylinderschraube Tornillo cilíndrico	Cheese head screw Vis à tête cylindrique	M6 x 25	DIN912
18	5000202422	2	pc	Innensechskantschraube Tornillo a seis lados huecos	Hexagon socket head screw Vis à six pans creux	M6 x 30	
19	5000107546	2	pc	Spannstift Pasador	Roll pin Goupille de tension	8 x 12	
20	5000106531	1	pc	Zahnrad Engranaje	Gear wheel Roue dentée		
21	5100002772	2	pc	Sicherungsscheibe Arandela de seguridad	Lock washer Rondelle d'arrêt		
22	5000099416	1	pc	Scheibe Arandela	Washer Rondelle	0,5	
22	5000217100	1	pc	Scheibe Disco	Washer Rondelle	0,3	
23	5100030401	1	pc	Ölpumpe Bomba de aceite	Oil pump Pompe à huile		

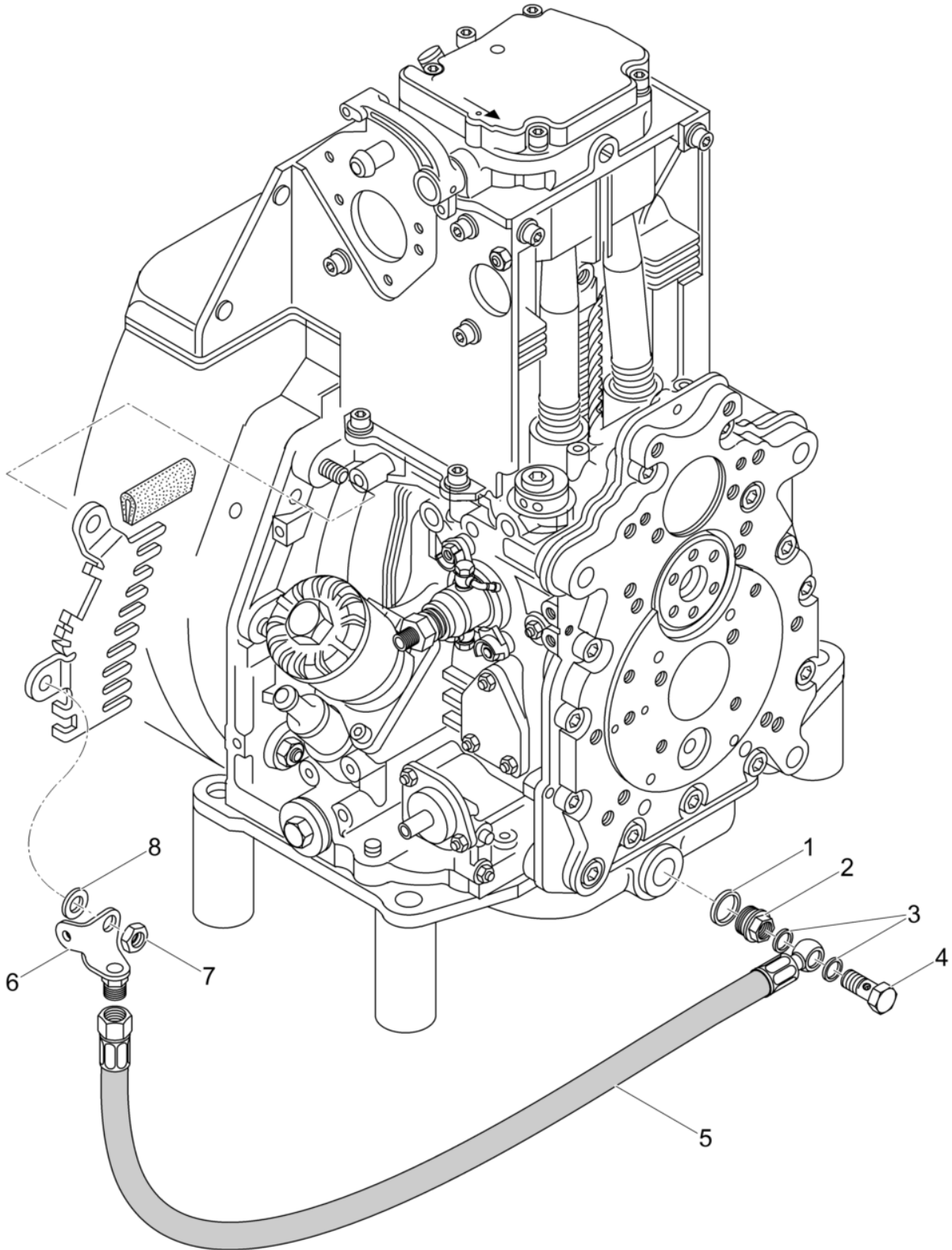

Pos. Item	Artikel Nr. Item no.	Pc.	Unit	Beschreibung Descripción	Description Description	Abm. Dim.	Norm Standard
						Drehmoment Torque	Schmierstoff Lubricant
1	5000202416	1	pc	Öldichtung Junta de aceite	Oil seal Joint d'huile	52 x 80 x 10	
2	5000104406	1	pc	Verschlusschraube Tornillo de cierre	Screw plug Vis de fermeture		
3	5000012624	2	pc	Dichtring Anillo de junta	Gasket Bague d'étanchéité	A14 x 18	DIN7603
4	5000203656	1	pc	Hohlschraube Perno hueco	Banjo bolt Boulon creux à filet femelle	10-3	
5	5000217092	1	pc	Schlauchleitung M. Ölablass Conducto flexible drenaje de aceite	Hose pipe oil drain Conduite flexible raccord		
6	5000126074	1	pc	Halter Soporte	Retainer Logement		
7	5000207530	1	pc	Sechskantmutter Contratuerca	Locknut Contre-écrou	M12	
8	5000203132	1	pc	Scheibe Arandela	Washer Rondelle	A13	

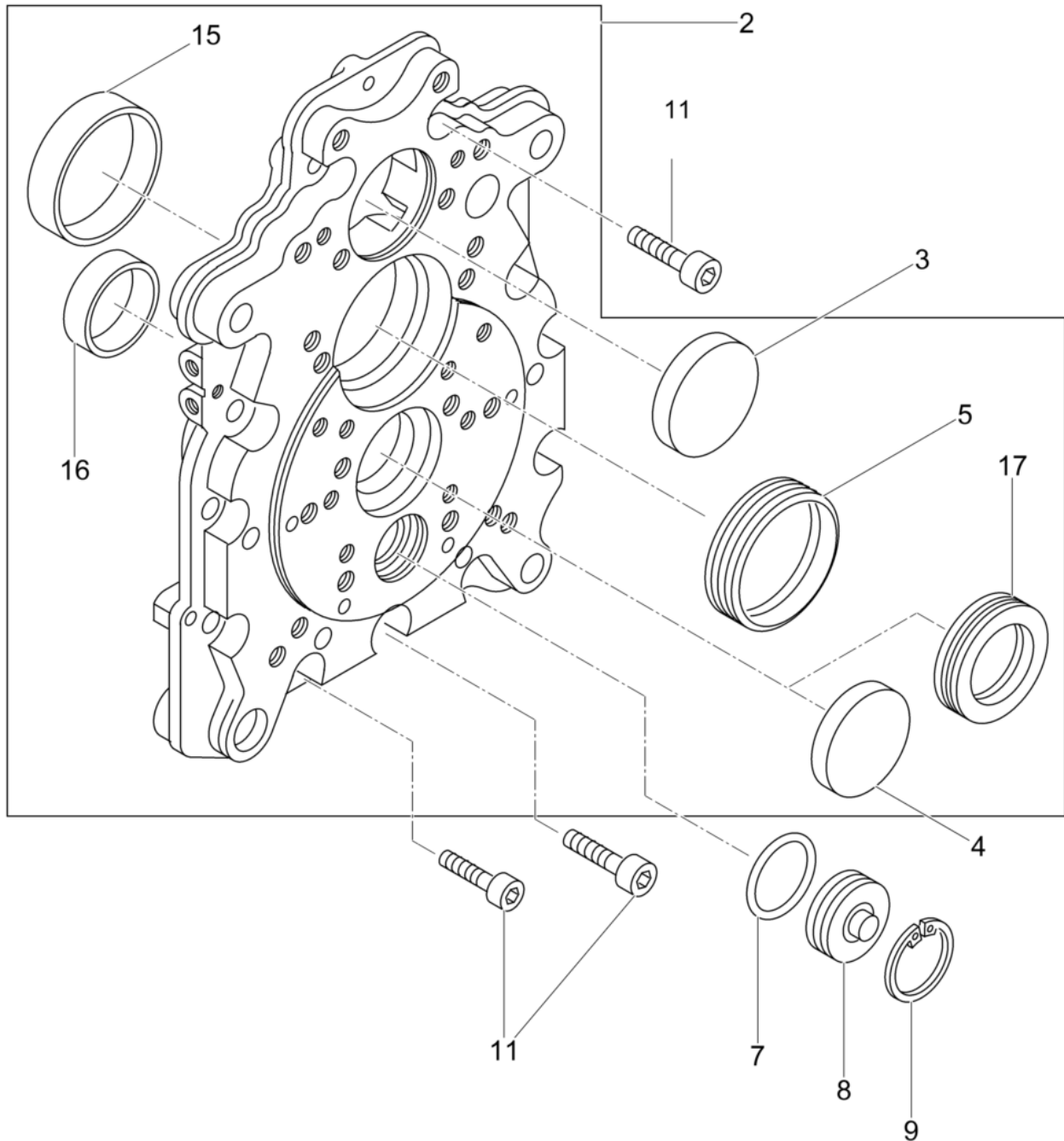

Pos. Item	Artikel Nr. Item no.	Pc.	Unit	Beschreibung Descripción	Description Description	Abm. Dim.	Norm Standard
						Drehmoment Torque	Schmierstoff Lubricant
2	5000207594	1	pc	Steuerdeckel Tapa del mando	Command cover Couvercle de commande		
3	5000095014	1	pc	Verschlußdeckel Tapa	Cover Couvercle		
4	5000095015	1	pc	Verschlußdeckel Tapa	Cover Couvercle		
5	5000095013	1	pc	Wellendichtring Sello del eje	Shaft seal Bague d'étanchéité		
7	5000095016	1	pc	O-Ring Anillo-o	O-ring Joint torique		
8	5000095017	1	pc	Deckel Tapa	Cover Couvercle		
9	5000202455	1	pc	Sicherungsring Anillo de retención	Retaining ring Bague d'arrêt	32 x 1,2	
11	5000202462	13	pc	Innensechskantschraube Tornillo a seis lados huecos	Hexagon socket head screw Vis à six pans creux	M8 x 30	
15	5000095012	1	pc	Gleitlager Rodamiento	Bearing Roulement		
16	5000202385	1	pc	Lagerbuchse Casquillo del cojinete	Bearing bush Bôte de roulement		
17	5000207607	1	pc	Wellendichtring Anillo de retén radial	Rotary shaft seal Bague d'étanchéité		

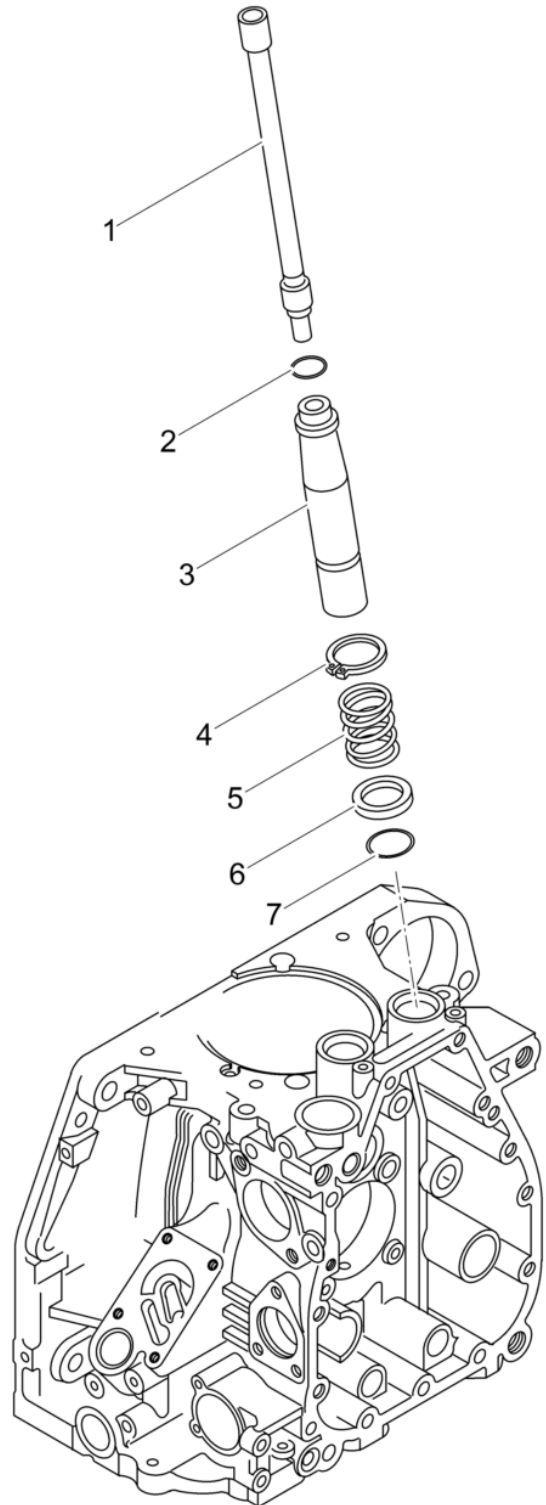
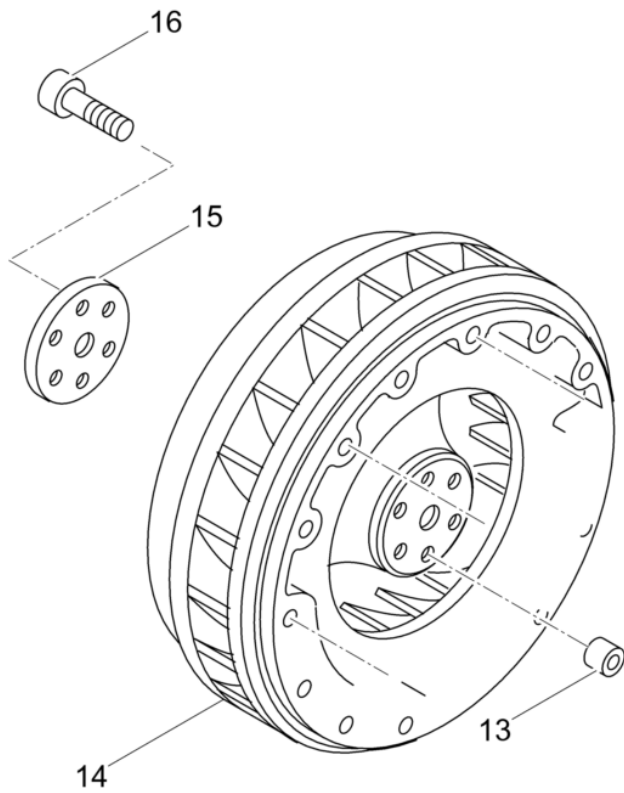

Pos. Item	Artikel Nr. Item no.	Pc.	Unit	Beschreibung Descripción	Description Description	Abm. Dim.	Norm Standard
						Drehmoment Torque	Schmierstoff Lubricant
1	5000098457	2	pc	Stoßstange Levantaválvula	Push rod (valve lifter) Poussoir de soupape		
2	5100051913	2	pc	O-Ring Anillo-o	O-ring Joint torique		
3	5000094943	2	pc	Rohr Tubo	Pipe Tube		
4	5000094942	2	pc	Sicherungsring Anillo de retención	Retaining ring Bague d'arrêt	24 x 1,75	DIN471
5	5000094941	2	pc	Feder Resorte	Spring Ressort		
6	5000094940	2	pc	Scheibe Arandela	Washer Rondelle		
7	5000094939	2	pc	O-Ring Anillo-o	O-ring Joint torique		
13	5000095044	1	pc	Fixierhülse Manguito	Sleeve Douille		
14	5000097446	1	pc	Schwungrad Volante	Flywheel Volant		
15	5000095045	1	pc	Fixierscheibe Disco	Disc holder Disque		
16	5000095046	6	pc	Zylinderschraube Tornillo cilíndrico	Cheese head screw Vis à tête cylindrique	M12 x 1,5 x 40 120Nm/89ft.lbs	ISO4762

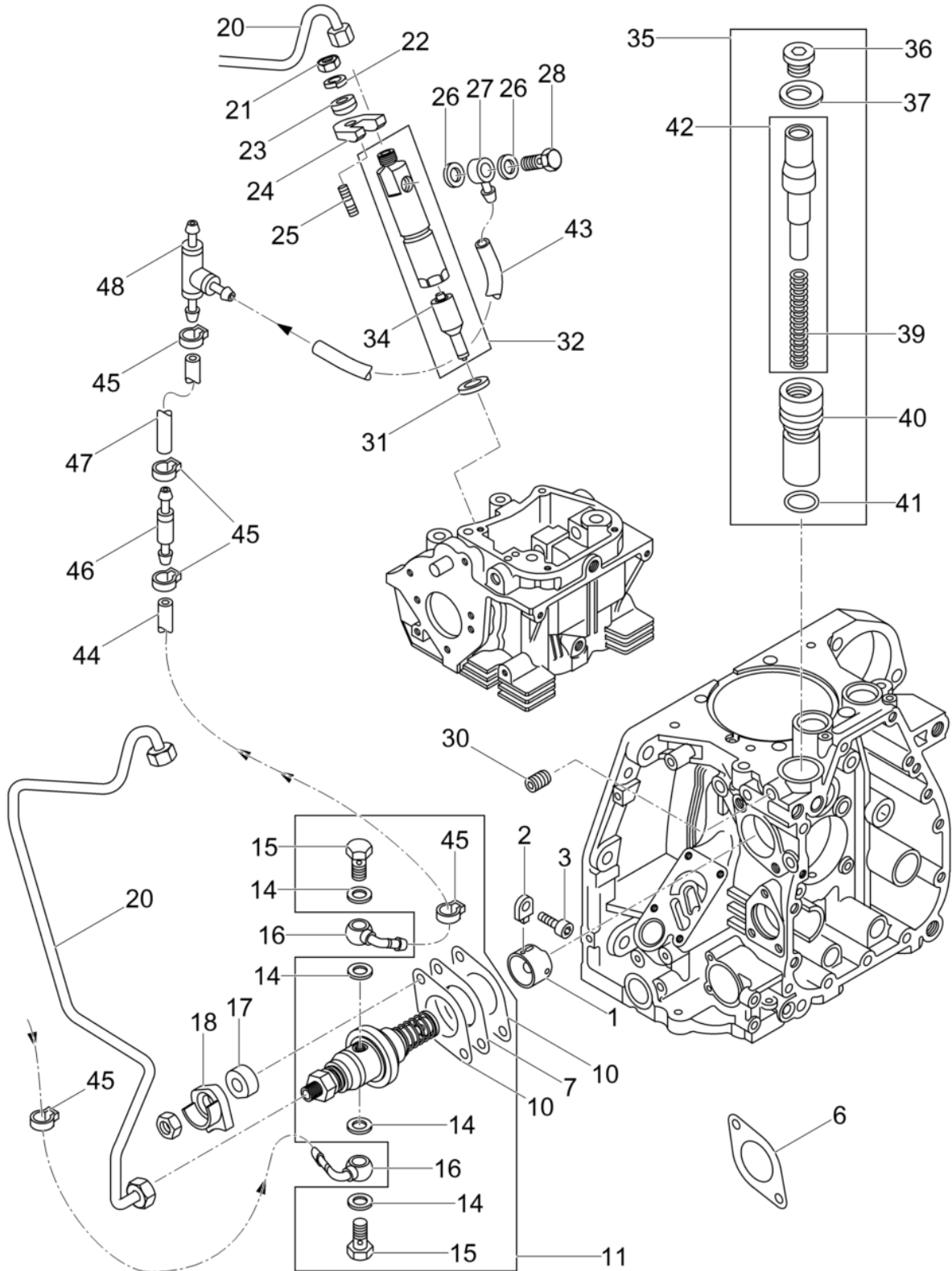

Pos. Item	Artikel Nr. Item no.	Pc.	Unit	Beschreibung Descripción	Description Description	Abm. Dim.	Norm Standard
						Drehmoment Torque	Schmierstoff Lubricant
1	5100051905	1	pc	Stößel Botador	Tappet Pousoir		
2	5000126526	1	pc	Führung Guía	Guide Guide		
3	5000207610	1	pc	Zylinderschraube Tornillo cilíndrico	Cheese head screw Vis à tête cylindrique	M6 x 16	
6	5000014482	1	pc	Ausgleichsscheibe Laminilla	Shim Cale	0,3	
7	5000207532	1	pc	Ausgleichsscheibe Laminilla	Shim Cale	0,6	
7	5000207533	1	pc	Ausgleichsscheibe Laminilla	Shim Cale	0,9	
7	5000207534	1	pc	Ausgleichsscheibe Laminilla	Shim Cale	1,2	
10	5000099419	1	pc	Dichtung Junta	Gasket Joint	0.1	
10	5000207543	1	pc	Dichtung Junta	Gasket Joint	0.2	
10	5000207544	1	pc	Dichtung Junta	Gasket Joint	0.3	
11	5100051945	1	pc	Einspritzpumpe Bomba inyectora	Injection pump Pompe d'injection		
14	5000215374	4	pc	Dichtring Anillo sellante	Seal ring Bague d'étanchéité		
15	5000210452	2	pc	Hohlschraube Tornillo hueco	Hollow screw Boulon creux à filet femelle	M 8x 1	
16	5000207809	1	pc	Anschraubnippel Boquilla roscada	Screw nipple Raccord de vissage		
17	5000207555	2	pc	Distanzstück Pieza distanciadora	Spacer Pièce d'écartement		
18	5000207592	2	pc	Spannpratze Abrazadera de clamping	Clamping clamp Bride de clamping		
20	5000207571	1	pc	Kraftstoffdruckrohr Tubo	Pipe Tube		
21	5000151379	1	pc	Sechskantmutter Contratuercas	Locknut Contre-écrou	M8	ISO4032
22	5000151218	1	pc	Federring Arandela elástica	Lock washer Rondelle de ressort	8	
23	5000095021	1	pc	Kugelscheibe Disco	Disc Disque		
24	5000095022	1	pc	Halter Soporte	Holder Attache		
25	5000207595	1	pc	Stiftschraube Perno prisionero	Stud Boulon	M8 x 35	
26	5000128957	2	pc	Dichtring Anillo de junta	Gasket Bague détanchéité		
27	5000095020	1	pc	Nippel Unión	Fitting Raccord		
28	5000095019	1	pc	Hohlschraube Perno hueco	Banjo bolt Boulon creux à filet femelle		
30	5000020348	1	pc	Gewindestift Varilla roscada	Threaded pin Goupille fileté	M8 x 16	DIN916
31	5000217099	1	pc	Dichtring Anillo sellante	Seal ring Bague d'étanchéité		
32	5100013806	1	pc	Einspritzventil Válvula de inyección	Injection valve Soupape d'injection		

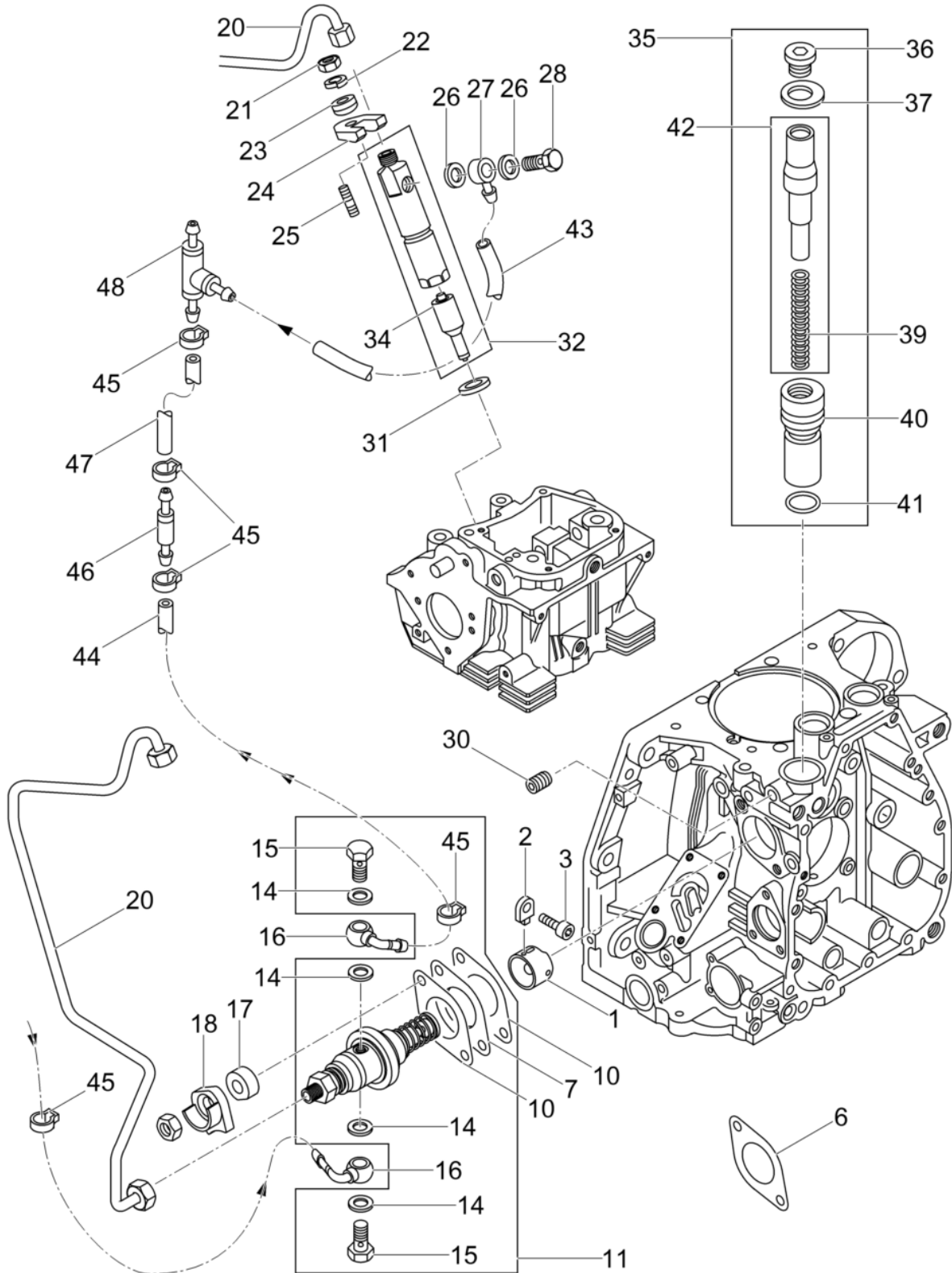

Pos. Item	Artikel Nr. Item no.	Pc.	Unit	Beschreibung Descripción	Description Description	Abm. Dim.	Norm Standard
						Drehmoment Torque	Schmierstoff Lubricant
34	5100013807	1	pc	Düse Chicler	Jet Gicleur		
35	5000095007	1	pc	Gehäuse Carcasa	Housing Carter		
36	5000207601	1	pc	Verschlusschraube Tapón roscado	Screw plug Vis de fermeture		
37	5000095006	1	pc	Scheibe Arandela	Washer Rondelle		
39	5000207556	1	pc	Feder Resorte	Spring Ressort		
40	5000207609	1	pc	Gehäuse Carcasa	Housing Carter		
41	5000095008	1	pc	O-Ring Anillo-o	O-ring Joint torique	22,0 x 1,6	
42	5000095009	1	pc	Steuerteil Elemento de mando	Steering part Régulateur		
43	5000209727	1	pc	Kraftstoffleitung Manguera de combustible	Fuel hose Tuyau de carburant		
44	5100018092	1	pc	Kraftstoffleitung Manguera de combustible	Fuel hose Tuyau à essence	6x135	
45	5000207586	4	pc	Schlauchklemme Abrazadera	Clamp Collier de serrage		
46	5000047977	1	pc	Ventil Unión	Hose fitting Raccord		
47	5000217101	1	pc	Kraftstoffleitung Manguera de combustible	Fuel hose Tuyau à essence	4,5 x 170	
48	5000099417	1	pc	T-Stück Unión forma t	Tee-fitting Raccord "t"		

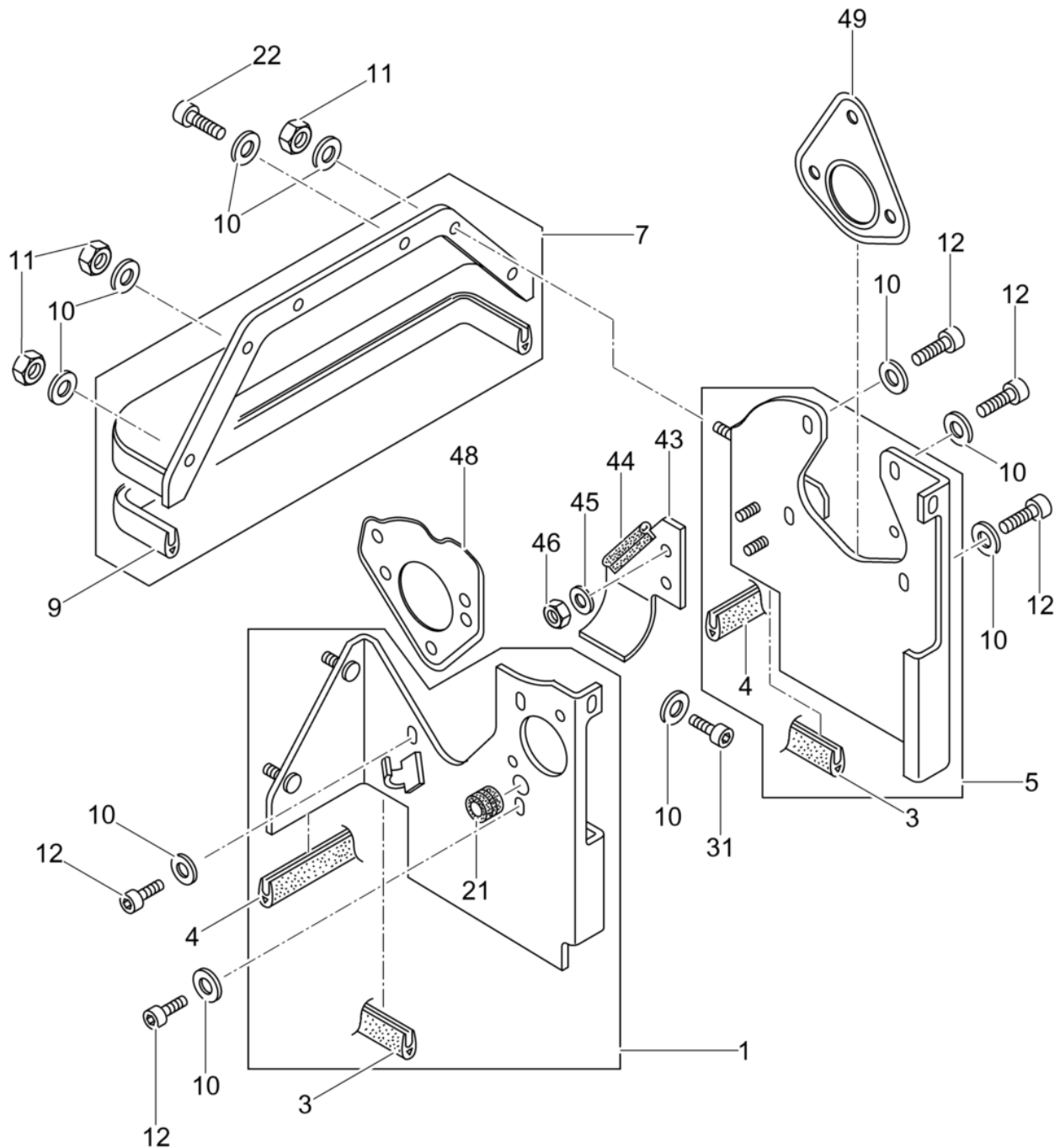

Pos. Item	Artikel Nr. Item no.	Pc.	Unit	Beschreibung Descripción	Description Description	Abm. Dim.	Norm Standard
						Drehmoment Torque	Schmierstoff Lubricant
1	5000098460	1	pc	Verkleidung Links Tapa-izquierda	Left cover Couvercle-gauche		
3	5000105050	2	pc	Dichtungsprofil Junta	Profiled joint Joint d'étanchéité profilé		
4	5000105051	2	pc	Dichtungsprofil Junta	Profiled joint Joint d'étanchéité profilé		
5	5000207579	1	pc	Luftleitblech Deflector	Baffle Déflecteur		
7	5000095035	1	pc	Verkleidung Tapa	Cover Couvercle		
9	5000095036	1	pc	Dichtungsprofil Empaque	Seal Joint		
10	5000207593	15	pc	Spannscheibe Arandela elástica	Spring washer Disque de serrage		
11	5000151323	4	pc	Sechskantmutter Contratuerca	Locknut Contre-écrou	M6	ISO4032
12	5000202304	7	pc	Zylinderschraube Tornillo cilíndrico	Cheese head screw Vis à tête cylindrique	M6 x 16	DIN6912
21	5000107379	1	pc	Gummitülle Ojal	Grommet Passe-fil		
22	5000201380	2	pc	Zylinderschraube Tornillo cilíndrico	Cheese head screw Vis à tête cylindrique	M6 x 16	
31	5000201380	2	pc	Zylinderschraube Tornillo cilíndrico	Cheese head screw Vis à tête cylindrique	M6 x 16	
43	5000207581	1	pc	Luftleitblech Deflector	Baffle Déflecteur		
44	5000207540	1	pc	Dichtleiste Empaque	Seal Joint		
45	5000151540	2	pc	Scheibe Arandela	Washer Rondelle	A6,4	DIN9021
46	5000129021	2	pc	Sechskantmutter Contratuerca	Locknut Contre-écrou	VM6	
48	5000207554	1	pc	Dichtung Junta	Gasket Joint		
49	5000207553	1	pc	Dichtung Junta	Gasket Joint		

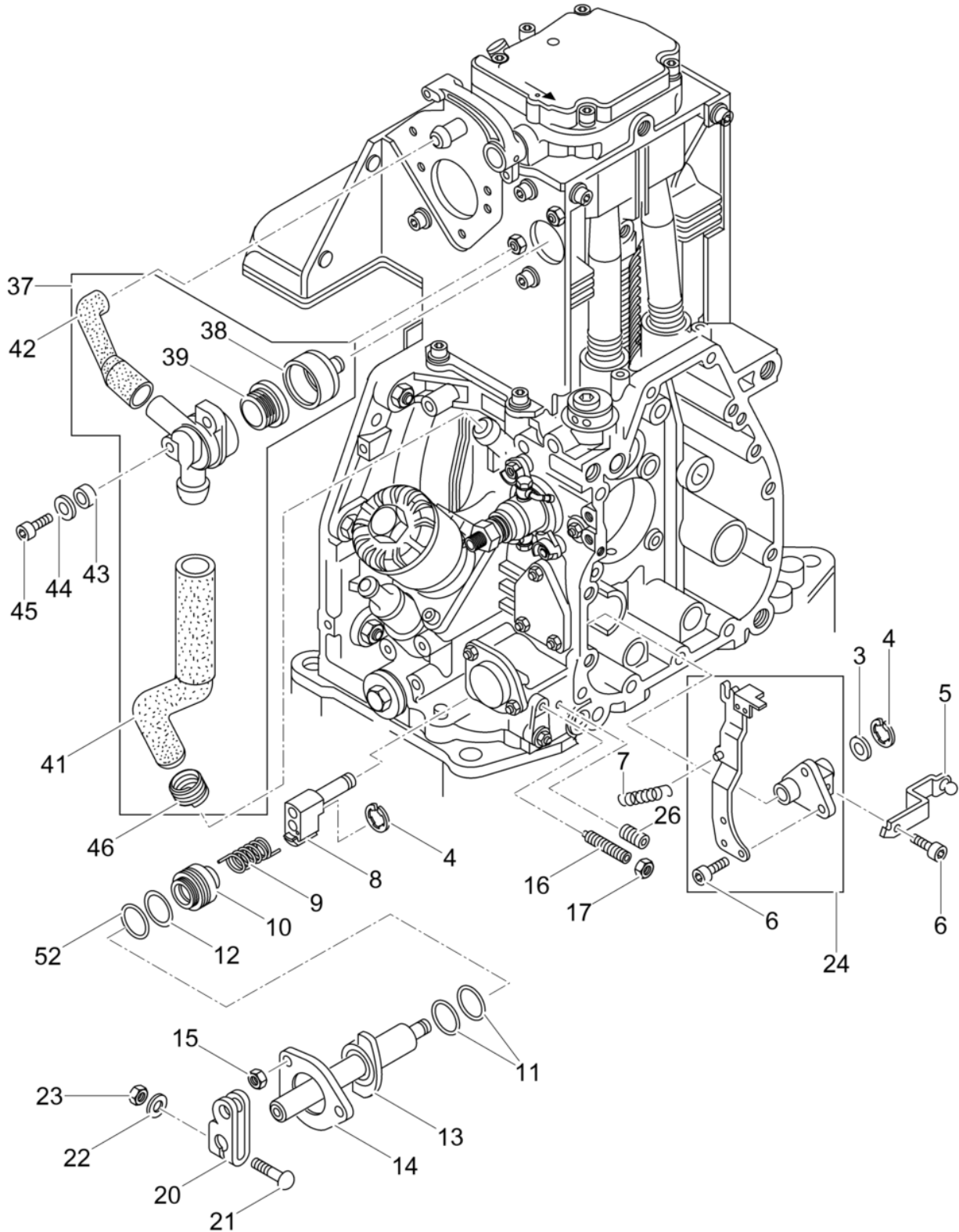

Pos. Item	Artikel Nr. Item no.	Pc.	Unit	Beschreibung Descripción	Description Description	Abm. Dim.	Norm Standard
						Drehmoment Torque	Schmierstoff Lubricant
3	5000094970	1	pc	Scheibe Arandela	Washer Rondelle		
4	5000202444	2	pc	Sicherungsscheibe Arandela de seguridad	Lock washer Rondelle d'arrêt	6,0	
5	5000094969	1	pc	Reglerhebel Palanca de regulador	Governor lever Levier régulateur		
6	5000202449	4	pc	Innensechskantschraube Tornillo a seis lados huecos	Hexagon socket head screw Vis à six pans creux	M5 x 8	
7	5000094966	1	pc	Feder Resorte	Spring Ressort		
8	5000097417	1	pc	Führung Guía	Guide Guide		
9	5000097416	1	pc	Torsionsfeder Resorte	Torsion spring Ressort		
10	5000202395	1	pc	Abstandsring Anillo distanciador	Distance ring Bague intermediaire		
11	5000202459	2	pc	O-Ring Anillo-o	O-ring Joint torique	18 x 2	
12	5000094963	1	pc	O-Ring Anillo-o	O-ring Joint torique		
13	5000202371	1	pc	Welle Eje	Shaft Arbre		
14	5000103080	1	pc	Flansch Brida	Flange Bride		
15	5000129021	3	pc	Sechskantmutter Contratuercas	Locknut Contre-écrou	VM6	
16	5100013812	2	pc	Gewindestift Varilla roscada	Threaded pin Goupille fileté	M6x45	
17	5000151323	1	pc	Sechskantmutter Contratuercas	Locknut Contre-écrou	M6	ISO4032
20	5000104407	1	pc	Hebel Palanca	Lever Levier		
21	5000094960	1	pc	Halbrundschaube Tornillo	Screw Vis		
22	5000151324	1	pc	Scheibe Arandela	Washer Rondelle	6.4	
23	5000207588	1	pc	Sechskantmutter Contratuercas	Locknut Contre-écrou	M6	
24	5000126519	1	pc	Reglerhebel Kpl. Palanca de regulador cpl.	Governor lever cpl. Levier régulateur cpl.		
26	5000202456	1	pc	Gewindestift Varilla roscada	Threaded pin Goupille fileté	M8 x 20	
37	5000207561	1	pc	Entlüftungsventil Válvula purgadora	Bleeder valve Soupape de purge de l'air		
38	5000098461	1	pc	Kappe Tapa	Cap Couvercle		
39	5100051941	1	pc	Membran Diafragma	Diaphragm Diaphragme		
41	5000098463	1	pc	Schlauch Manguera	Hose Tuyau		
42	5000098462	1	pc	Entlüftungsschlauch Línea de purgado	Breather tube Tuyau d'évacuation purge		
43	5000098465	2	pc	Buchse Buje	Bushing Douille		
44	5000151290	2	pc	Federscheibe Arandela elástica	Spring washer Rondelle à ressort	A6	DIN137

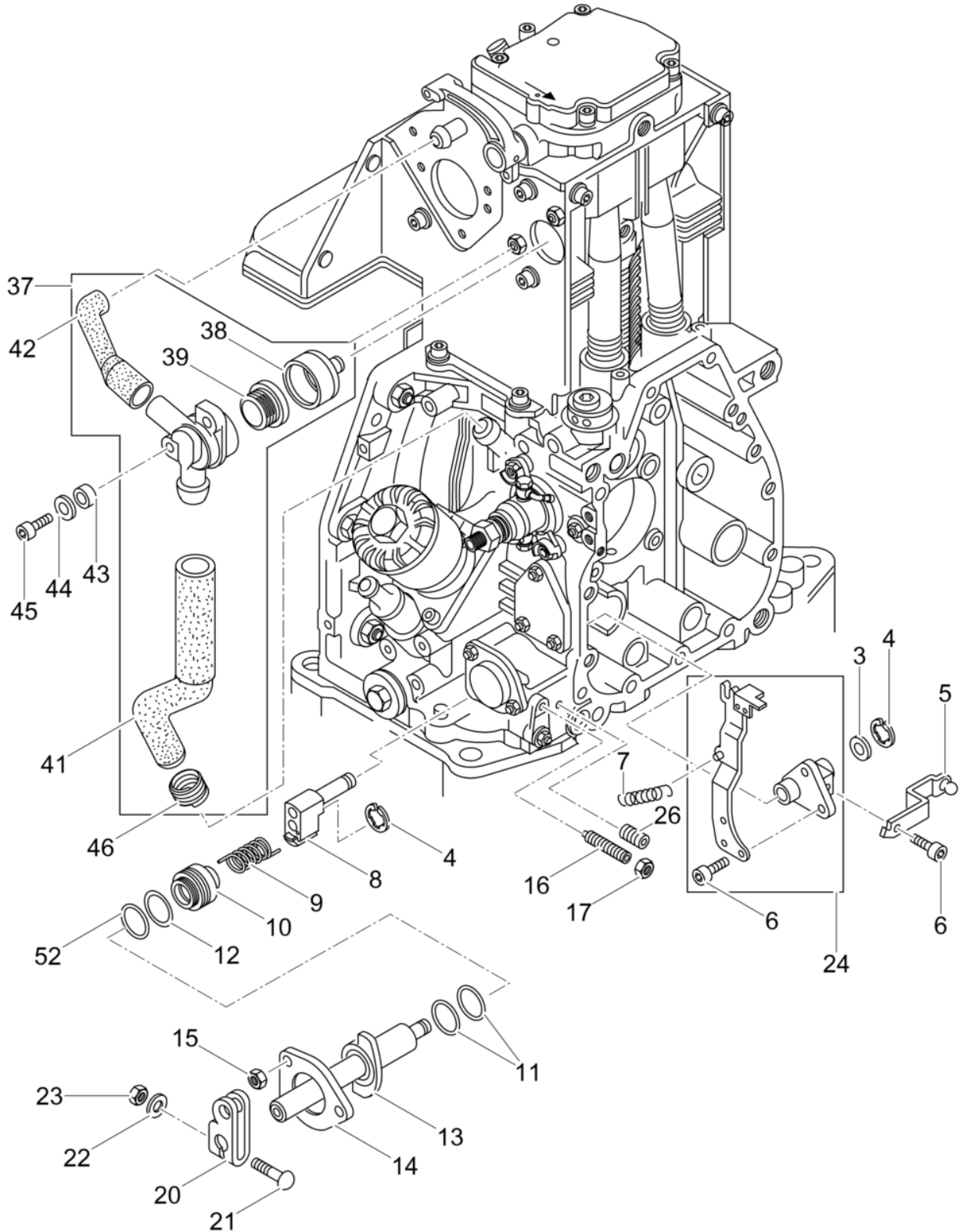

Pos. Item	Artikel Nr. Item no.	Pc.	Unit	Beschreibung Descripción	Description Description	Abm. Dim.	Norm Standard
						Drehmoment Torque	Schmierstoff Lubricant
45	5000151231	2	pc	Zylinderschraube Tornillo cilíndrico	Cheese head screw Vis à tête cylindrique	M6 x 16	ISO4762
46	5000102470	1	pc	Federklemme Borne de contacto elástico	Clip Pince de ressort		
52	5000202466	1	pc	Ring Anillo	Ring Bague	32 x 45 x 2.5	

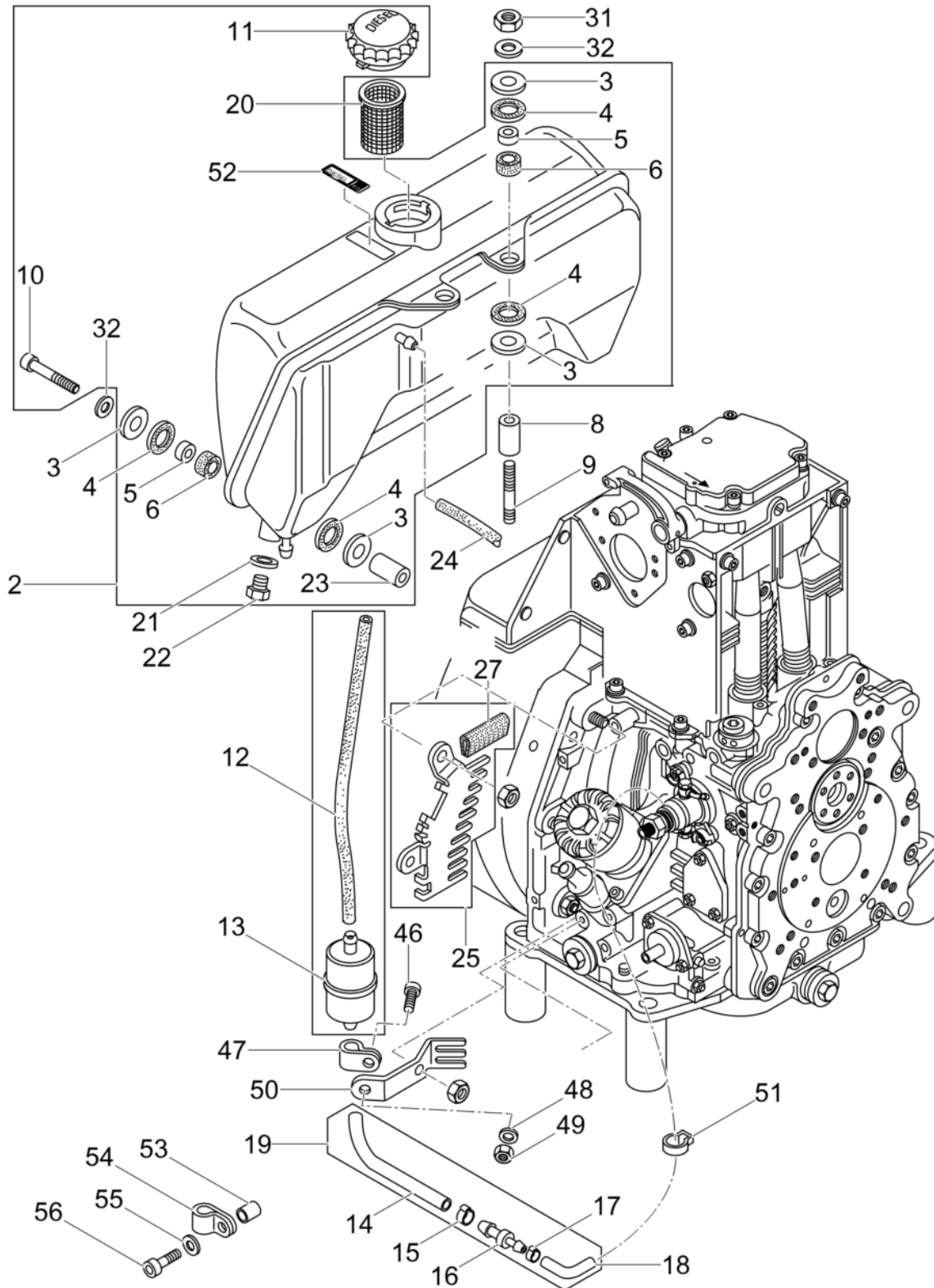

Pos. Item	Artikel Nr. Item no.	Pc.	Unit	Beschreibung Descripción	Description Description	Abm. Dim.	Norm Standard
						Drehmoment Torque	Schmierstoff Lubricant
2	5000095081	1	pc	Kraftstofftank Tanque de combustible	Fuel tank Réservoir de carburant		
3	5000151344	12	pc	Scheibe Arandela	Washer Rondelle		
4	5000095355	12	pc	Gummischeibe Arandela	Washer Rondelle		
5	5000095356	6	pc	Buchse Buje	Bushing Douille		
6	5000095357	6	pc	Gummihülse Manguito	Sleeve Douille		
8	5000095082	2	pc	Buchse Buje	Bushing Douille		
9	5000031063	2	pc	Stiftschraube Tornillo espárrago	Stud bolt Goupille fileté	M8 x 75	DIN835
10	5000207613	4	pc	Zylinderschraube Tornillo cilíndrico	Cheese head screw Vis à tête cylindrique	M8 x 40	
11	5000099523	1	pc	Tankverschluß Tapa	Cap Couvercle	60	
12	5100051942	1	pc	Kraftstoffschlauch Manguera de combustible	Fuel hose Tuyau à essence		
13	5100046186	1	pc	Dieselfilter-Einsatz Diesel cartucho filtrante	Diesel filter insert Diesel element filtrant		
14	5000217991	1	pc	Kraftstoffleitung Manguera de combustible	Fuel hose Tuyau à essence	7x180	
15	5000203655	1	pc	Schlauchklemme Abrazadera	Clamp Collier de serrage	16,00	
16	5000207583	1	pc	Nippel Boquilla roscada	Nipple Raccord fileté		
17	5000207586	1	pc	Schlauchklemme Abrazadera	Clamp Collier de serrage		
18	5100032126	1	pc	Kraftstoffleitung Manguera de combustible	Fuel hose Tuyau à essence		
19	5100051958	1	pc	Kraftstoffschlauch Kpl. Manguera de combustible cpl.	Fuel hose cpl. Tuyau à essence cpl.		
20	5000095358	1	pc	Sieb Tamizador	Fuel strainer Filtre-tamis à carburant	50	
21	5000020071	1	pc	Dichtring Anillo de junta	Gasket Bague d'étanchéité	A10 x 14	DIN7603
22	5000202413	1	pc	Schraubverschluß Cierre roscada	Screw locking Fermeture de vissage		
23	5000099786	4	pc	Buchse Buje	Bushing Douille		
24	5000207574	1	pc	Kraftstoffleitung Tubería de combustible	Fuel pipe Tuyau à combustible	5 x 50in	
25	5000207536	1	pc	Berührungsschutz Dispositivo de protección	Contact safety device Grille de protection		
27	5000104421	1	pc	Dichtungsprofil Junta	Profiled joint Joint d'étanchéité profilé	29	
31	5000151379	2	pc	Sechskantmutter Contratuercas	Locknut Contre-écrou	M8	ISO4032
32	5000151218	6	pc	Federring Arandela elástica	Lock washer Rondelle de ressort	8	
46	5000202338	1	pc	Sechskantschraube Tornillo hexagonal	Hexagonal head cap screw Vis à tête hexagonale	M6 x 16	DIN933
47	5000107451	2	pc	Schelle Abrazadera	Clamp Agrafe		



Pos. Item	Artikel Nr. Item no.	Pc.	Unit	Beschreibung Descripción	Description Description	Abm. Dim.	Norm Standard
						Drehmoment Torque	Schmierstoff Lubricant
48	5000151324	1	pc	Scheibe Arandela	Washer Rondelle	6.4	
49	5000151323	1	pc	Sechskantmutter Contratuerca	Locknut Contre-écrou	M6	ISO4032
50	5000207537	1	pc	Berührungsschutz Dispositivo de protección	Contact safety device Grille de protection		
51	5000226598	1	pc	Schlauchklemme Abrazadera	Clamp Collier de serrage	12	
52	5000129791	1	pc	Aufkleber-Diesel Calcomanía-diesel	Decal-diesel Autocollant-diesel		
53	5000207522	1	pc	Distanzbüchse Caja distanciador	Spacer Douille d'écartement		
54	5000107451	1	pc	Schelle Abrazadera	Clamp Agrafe		
55	5000151456	1	pc	Federring Arandela elástica	Lock washer Rondelle de ressort	6	DIN128
56	5000129010	1	pc	Zylinderschraube Tornillo cilíndrico	Cheese head screw Vis à tête cylindrique	M6 x 25	DIN912

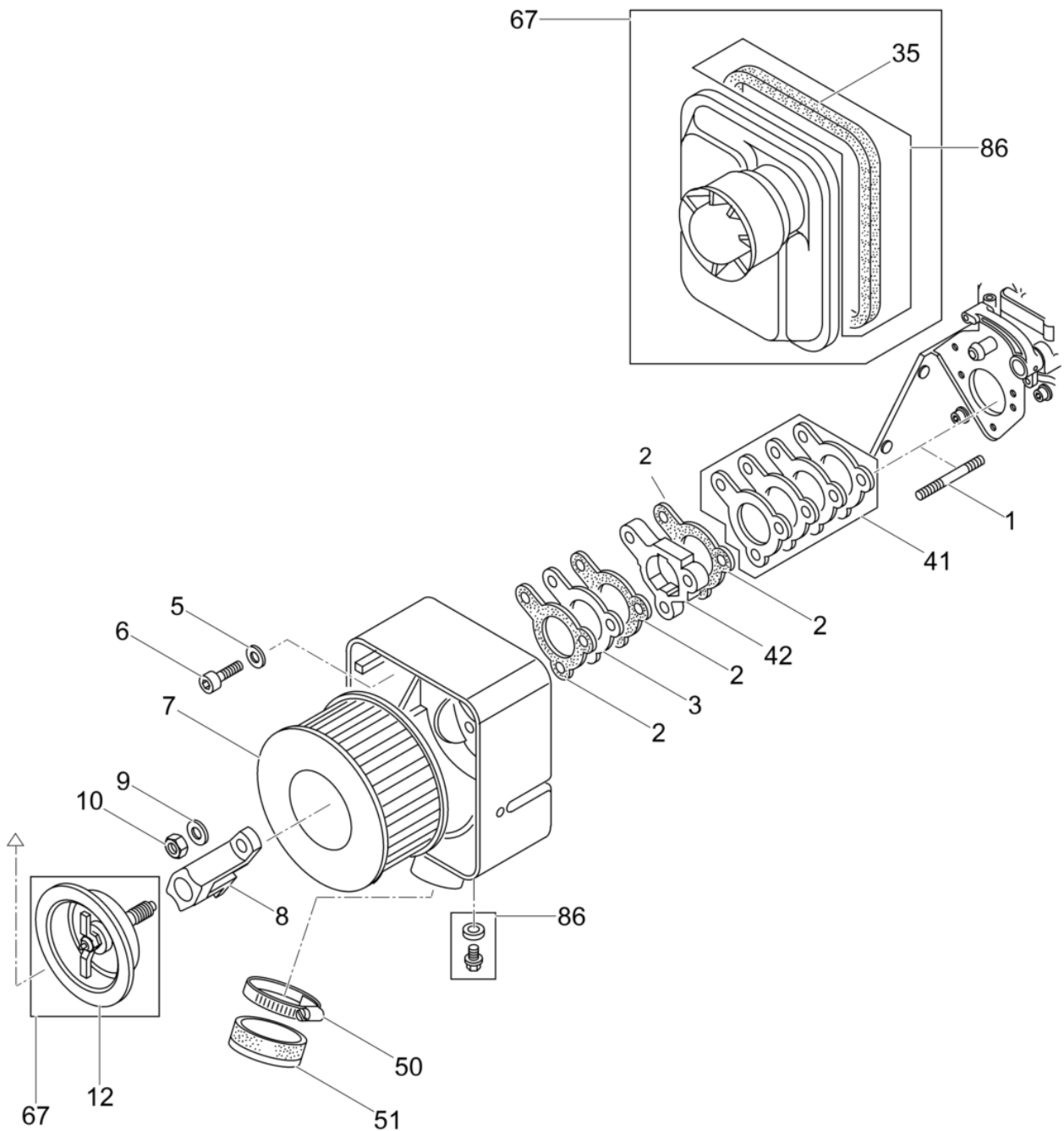

Pos. Item	Artikel Nr. Item no.	Pc.	Unit	Beschreibung Descripción	Description Description	Abm. Dim.	Norm Standard
						Drehmoment Torque	Schmierstoff Lubricant
1	5000207815	2	pc	Stiftschraube Perno prisionero	Stud Boulon	M8 x 60	
2	5000095088	3	pc	Dichtung Empaque	Seal Joint		
3	5000095089	1	pc	Isolierflansch Brida	Flange Collerette		
5	5200022048	1	pc	Tellerfeder Arandela de resorte	Spring washer Ressort belleville	A8	
6	5000207614	1	pc	Zylinderschraube Tornillo cilíndrico	Cheese head screw Vis à tête cylindrique	M8 x 45	
7	5100051954	1	pc	Luffilter Filtro del aire	Air cleaner Filtre à air		
8	5000099793	1	pc	Halter Soporte	Holder Attache		
9	5000151553	2	pc	Scheibe Arandela	Washer Rondelle	B8,4	ISO7089
10	5000129516	2	pc	Mutter Tuerca	Nut Erou	M8	
12	5100002774	1	pc	Filterdeckel Kpl. Tapa de filtro cpl.	Filter cover cpl. Couvercle de filtre cpl.		
35	5000097831	1	pc	Dichtung Empaque	Seal Joint		
41	5000097840	1	pc	Dichtungssatz Juego de juntas	Set-gaskets Jeu de joints		
42	5000097833	1	pc	Zwischenflansch Brida intermedia	Intermediate flange Bride intermediaire		
50	5000099804	1	pc	Schelle Abrazadera	Clamp Collier		
51	5000099803	1	pc	Abdeckkappe Tapa protectora	Cap Chape de protection		
67	5100002777	1	pc	Deckel Mit Zyklon Tapa con ciclón	Cover with cyclone Couvercle avec cyclone		
86	5100051955	1	pc	Luffiltergehäuse Carcasa filtro de aire	Air filter housing Carter de filtre		

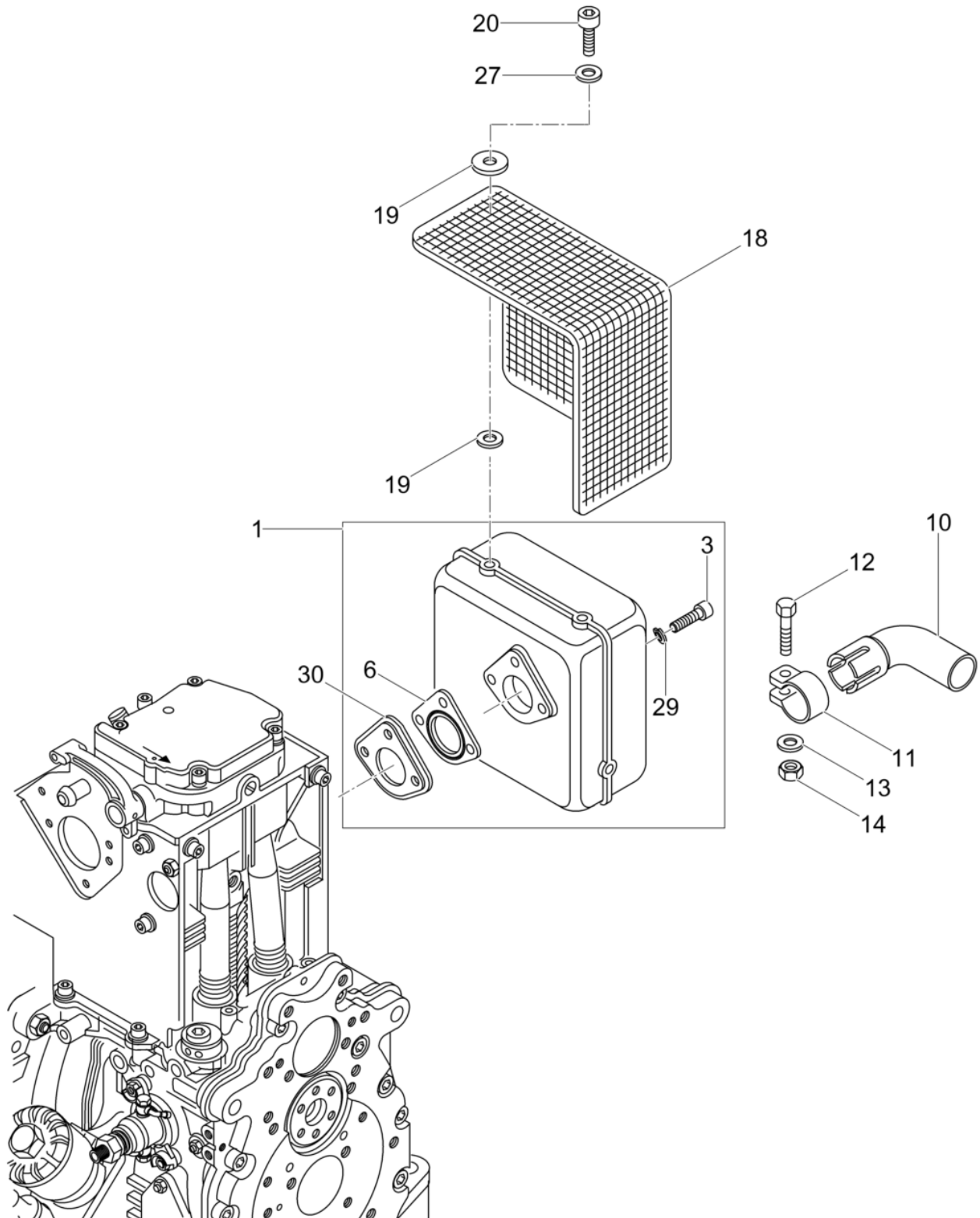

Pos. Item	Artikel Nr. Item no.	Pc.	Unit	Beschreibung Descripción	Description Description	Abm. Dim.	Norm Standard
						Drehmoment Torque	Schmierstoff Lubricant
1	5100001443	1	pc	Auspuff Kpl. Escape compl.	Exhaust kit Échappement compl.		
3	5000151578	3	pc	Zylinderschraube Tornillo cilíndrico	Cheese head screw Vis à tête cylindrique	M8 x 30	ISO4762
6	5100001033	1	pc	Dichtung Junta	Gasket Joint		
10	5000126956	1	pc	Abgasrohr Tubo de escape	Exhaust pipe Tubulare d'évacuation		
11	5000095100	1	pc	Schelle Abrazadera	Clamp Collier		
12	5000207591	1	pc	Sechskantschraube Tornillo hexagonal	Hexagonal head cap screw Vis à tête hexagonale	M10 x 50	
13	5000202434	1	pc	Scheibe Arandela	Washer Rondelle	10,5	
14	5000207589	1	pc	Sechskantmutter Contratuerca	Locknut Contre-écrou	VM10	
18	5000095098	1	pc	Berührungsschutz Protector	Guard Protecteur		
19	5000099525	10	pc	Scheibe Arandela	Washer Rondelle		
20	5000202443	5	pc	Zylinderschraube Tornillo cilíndrico	Cheese head screw Vis à tête cylindrique	M6 x 20	
27	5000151540	5	pc	Scheibe Arandela	Washer Rondelle	A6,4	DIN9021
29	5000151218	3	pc	Federring Arandela elástica	Lock washer Rondelle de ressort	8	
30	5000207553	1	pc	Dichtung Junta	Gasket Joint		

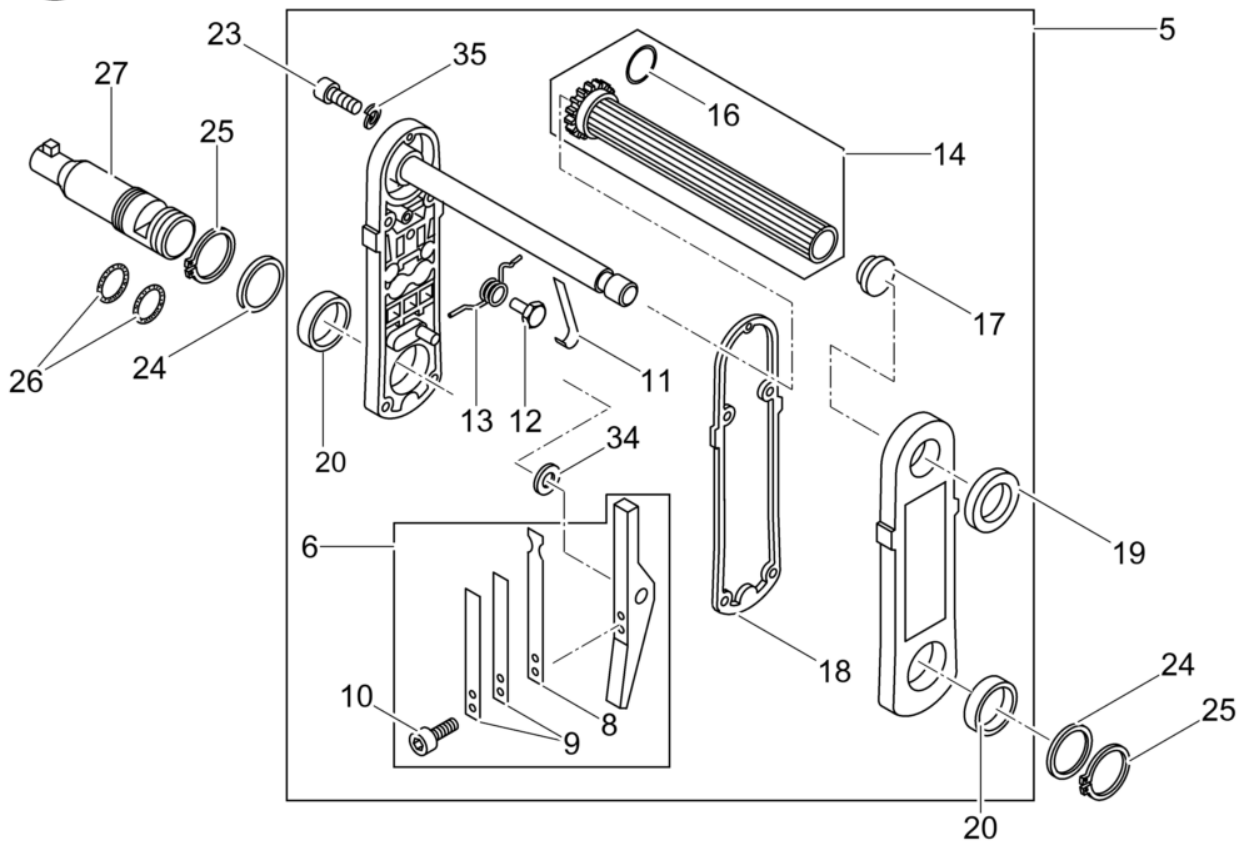
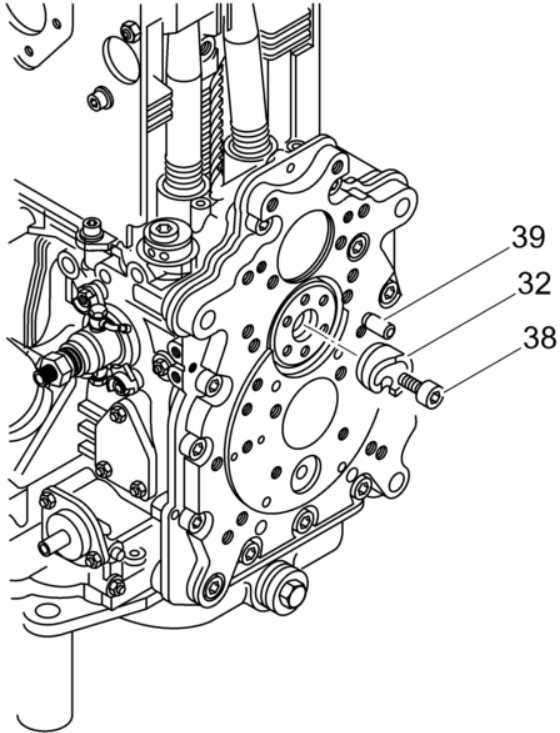

Pos. Item	Artikel Nr. Item no.	Pc.	Unit	Beschreibung Descripción	Description Description	Abm. Dim.	Norm Standard
						Drehmoment Torque	Schmierstoff Lubricant
5	5000210280	1	pc	Kurbel Manivela de arranque	Starting crank Manivelle de démarrage		
6	5000064064	1	pc	Hebel Palanca	Lever Levier		
8	5100051940	1	pc	Blattfeder Leaf spring	Leaf spring Ressort à lames		
9	5100051938	2	pc	Blattfeder Leaf spring	Leaf spring Ressort à lames		
10	5000049190	2	pc	Zylinderschraube Tornillo cilíndrico	Cheese head screw Vis à tête cylindrique	M5 x 8 10Nm/7ft.lbs	ISO4762
11	5100051936	1	pc	Blattfeder Leaf spring	Leaf spring Ressort à lames		
12	5100051935	1	pc	Sechskantschraube Tornillo hexagonal	Hexagonal head cap screw Vis à tête hexagonale		
13	5100051934	1	pc	Schenkelfeder Resorte de brazo	Leg spring Ressort coude		
14	5000069545	1	pc	Griffrohr Empuñadura	Tubular handle Poignée tubulaire		
16	5000105765	1	pc	O-Ring Anillo-o	O-ring Bague-o		
17	5000064062	1	pc	Stopfen Tapón	Plug Bouchon		
18	5100051939	1	pc	Dichtung Junta	Gasket Joint		
19	5100051916	1	pc	Wellendichtring Anillo de retén radial	Rotary shaft seal Bague d'étanchéité		
20	5100051917	2	pc	Buchse Buje	Bush Boîte		
23	5000203133	5	pc	Innensechskantschraube Tornillo a seis lados huecos	Hexagon socket head screw Vis à six pans creux	M6 x 25	
24	5100051937	1	pc	Passscheibe Arandela de ajuste	Shim ring Disque dajustage		
25	5100051915	2	pc	Sicherungsring Anillo de retención	Retaining ring Bague d'arrêt		
26	5100051914	2	pc	O-Ring Anillo-o	O-ring Joint torique		
27	5000107494	1	pc	Andrehwelle Garra de arranque	Starting shaft Arbre de mise en marche		
32	5000097419	1	pc	Andrehklaue Garra de arranque	Starting jaw Griffe de mise en marche		
34	5000064065	1	pc	Passscheibe Arandela de ajuste	Shim ring Disque d'ajustage	10 x 16 x 1	DIN988
35	5000151456	5	pc	Federring Arandela elástica	Lock washer Rondelle de ressort	6	DIN128
38	5000201372	1	pc	Innensechskantschraube Tornillo a seis lados huecos	Hexagon socket head screw Vis à six pans creux	M8x12	
39	5000202453	1	pc	Zylinderstift Pasador cilíndrico	Straight pin Goupille cylindrique		

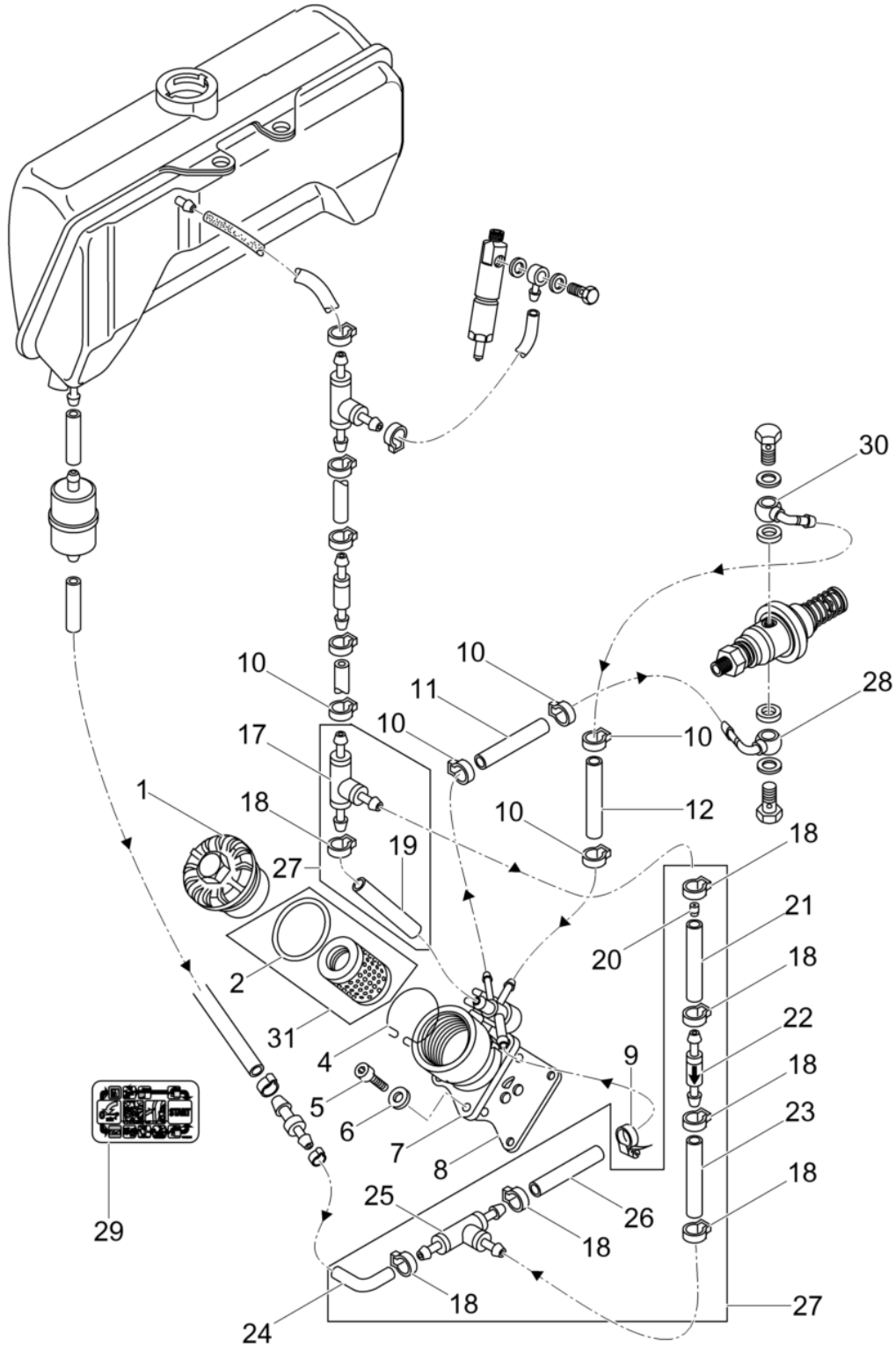

Pos. Item	Artikel Nr. Item no.	Pc.	Unit	Beschreibung Descripción	Description Description	Abm. Dim.	Norm Standard
						Drehmoment Torque	Schmierstoff Lubricant
1	5000094931	1	pc	Schraubdeckel Tapa	Cover Couvercle		
2	5000094928	1	pc	Flachdichtring Juntaaceite	Gasket Joint		
4	5000104402	1	pc	Drahtfeder Resorte	Spring Ressort		
5	5000202437	4	pc	Zylinderschraube Tornillo cilíndrico	Cheese head screw Vis à tête cylindrique	M6 x 20	
6	5000151290	4	pc	Federscheibe Arandela elástica	Spring washer Rondelle à ressort	A6	DIN137
7	5000207531	1	pc	Absperrventil Válvula de desconexión	Valve Soupape		
8	5000106559	1	pc	Dichtung Junta	Seal Joint		
9	5000202469	1	pc	Schlauchschelle Abrazadera	Clamp Agrafe		
10	5000207586	5	pc	Schlauchklemme Abrazadera	Clamp Collier de serrage		
11	5100030404	1	pc	Kraftstoffschlauch Manguera de combustible	Fuel hose Tuyau à essence		
12	5100018091	1	pc	Kraftstoffleitung Manguera de combustible	Fuel hose Tuyau à essence	6x110	
17	5000207810	1	pc	T-Stück Pieza t	T-piece T-pièce		
18	5000207586	7	pc	Schlauchklemme Abrazadera	Clamp Collier de serrage		
19	5000217104	1	pc	Kraftstoffleitung Manguera de combustible	Fuel hose Tuyau à essence	4,5 x 30	
20	5000207526	1	pc	Ventil Válvula	Valve Soupape		
21	5000217109	1	pc	Kraftstoffleitung Manguera de combustible	Fuel hose Tuyau à essence	5,3 x 50	
22	5000217093	1	pc	Rückschlagventil Válvula de retención	Back pressure valve Soupape de retenue		
23	5000217103	1	pc	Kraftstoffleitung Manguera de combustible	Fuel hose Tuyau à essence	4,5 x 80	
24	5000217106	1	pc	Kraftstoffleitung Manguera de combustible	Fuel hose Tuyau à essence	4,5 x 35	
25	5000106563	1	pc	T-Stück Unión forma t	Tee-fitting Raccord ""t""		
26	5000217105	1	pc	Kraftstoffleitung Manguera de combustible	Fuel hose Tuyau à essence	4,5 x 50	
27	5100051949	1	pc	Kraftstoffschlauch Kpl. Manguera de combustible cpl.	Fuel hose cpl. Tuyau à essence cpl.		
28	5000207525	1	pc	Anschraubnippel Boquilla roscada	Screw nipple Raccord de vissage		
29	5100030405	1	pc	Hinweisschild Placa indicadora	Information sign Plaque		
30	5000207809	1	pc	Anschraubnippel Boquilla roscada	Screw nipple Raccord de vissage		
31	5100051956	1	pc	Ölfilter Filtro de aceite	Oil filter Filtre d'huile		

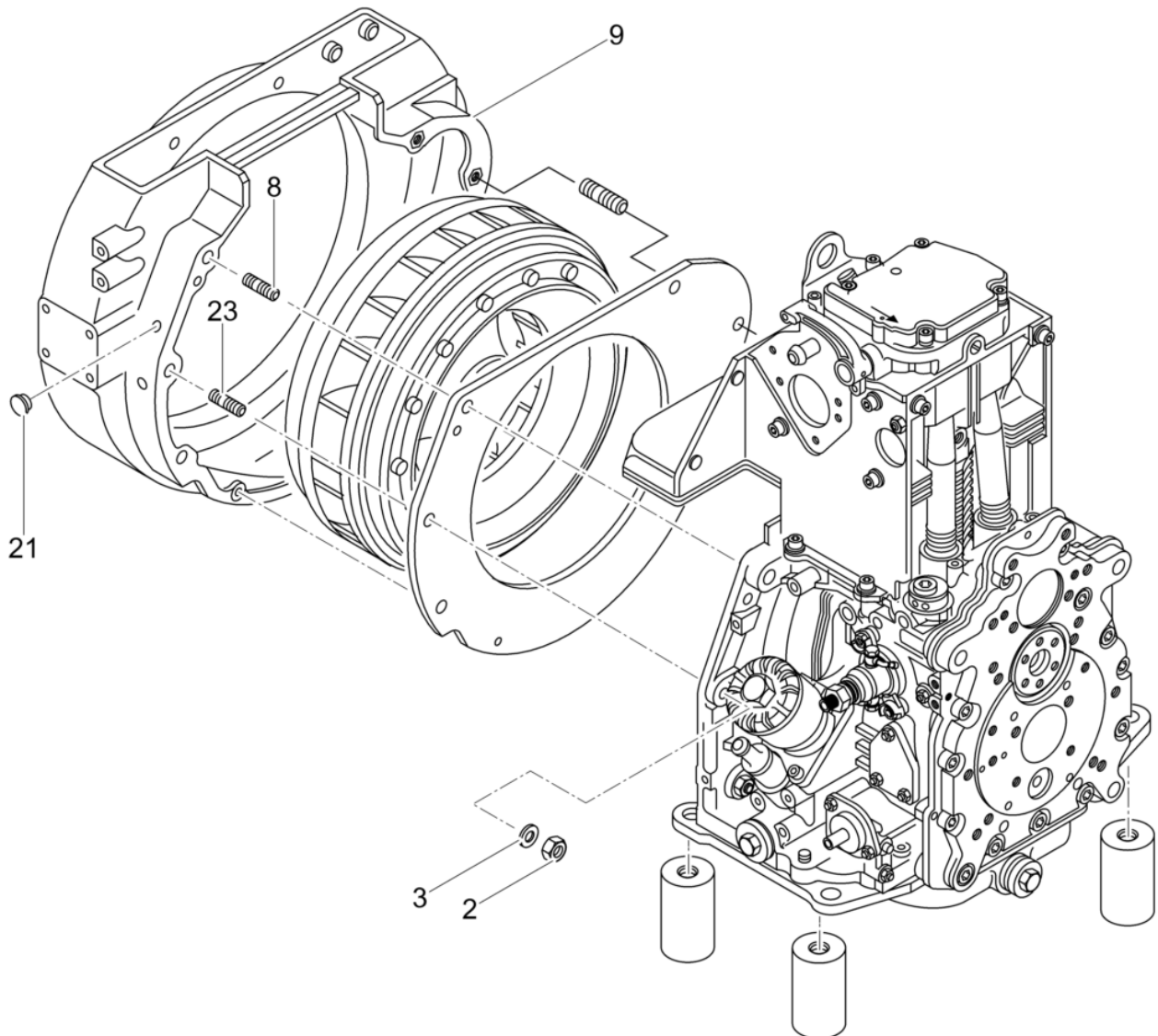

Pos. Item	Artikel Nr. Item no.	Pc.	Unit	Beschreibung Descripción	Description Description	Abm. Dim.	Norm Standard
						Drehmoment Torque	Schmierstoff Lubricant
2	5000207530	4	pc	Sechskantmutter Contratuercas	Locknut Contre-écrou	M12	
3	5000203132	4	pc	Scheibe Arandela	Washer Rondelle	A13	
8	5000010936	3	pc	Stiftschraube Tornillo espárrago	Stud bolt Goupille fileté	M12 x 35 86Nm/63ft.lbs	DIN835
9	5000095042	1	pc	Anschlußgehäuse Caja	Housing Carter		
21	5000207605	2	pc	Verschlussstopfen Tapón	Push-in plug Bouchon		
23	5000010937	1	pc	Stiftschraube Tornillo espárrago	Stud bolt Goupille fileté	M12 x 40	

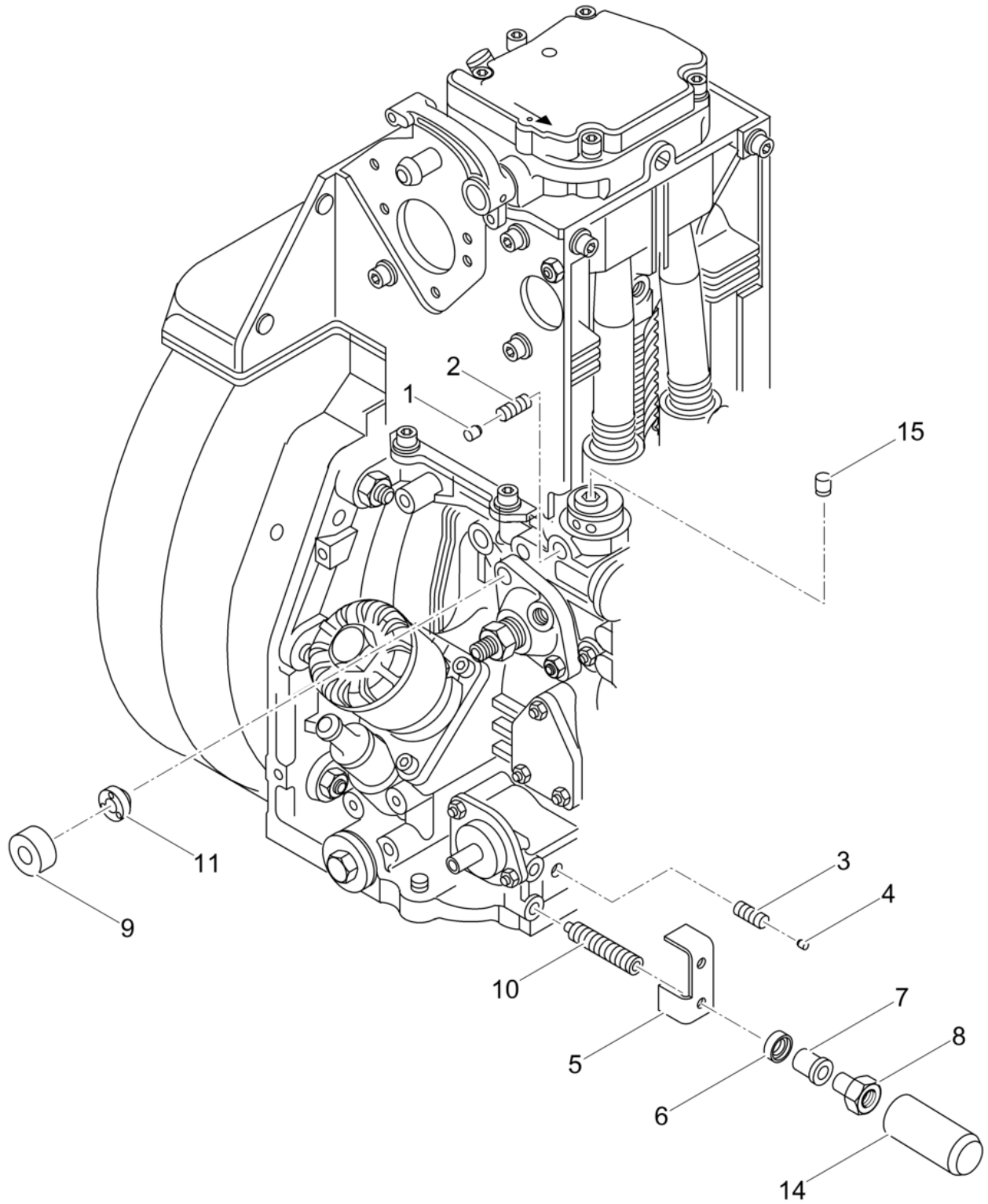

Pos. Item	Artikel Nr. Item no.	Pc.	Unit	Beschreibung Descripción	Description Description	Abm. Dim.	Norm Standard
						Drehmoment Torque	Schmierstoff Lubricant
1	5000207603	1	pc	Verschlußstopfen Tapón	Push-in plug Bouchon		
2	5000020348	1	pc	Gewindestift Varilla roscada	Threaded pin Goupille fileté	M8 x 16	DIN916
3	5000202456	1	pc	Gewindestift Varilla roscada	Threaded pin Goupille fileté	M8 x 20	
4	5000207604	1	pc	Verschlußstopfen Tapón	Push-in plug Bouchon		
5	5000126904	1	pc	Winkel Ángulo	Angle Coude		
6	5000126905	1	pc	Scheibe Arandela	Washer Rondelle		
7	5000126906	1	pc	Buchse Buje	Bush Boîte		
8	5000126907	1	pc	Gewindebuchse Casquillo roscado	Threaded bush Boîte tarandée	M6	
9	5000207567	2	pc	Kappe Tapa	Cap Couvercle		
10	5100013812	2	pc	Gewindestift Varilla roscada	Threaded pin Goupille fileté	M6x45	
11	5000207587	2	pc	Sicherheitsmutter Tuerca de seguridad	Counternut Ecrou de sécurité		
14	5000126911	1	pc	Kappe Tapa	Cap Chapeau		
15	5000207602	1	pc	Verschlußstopfen Tapón	Push-in plug Bouchon		

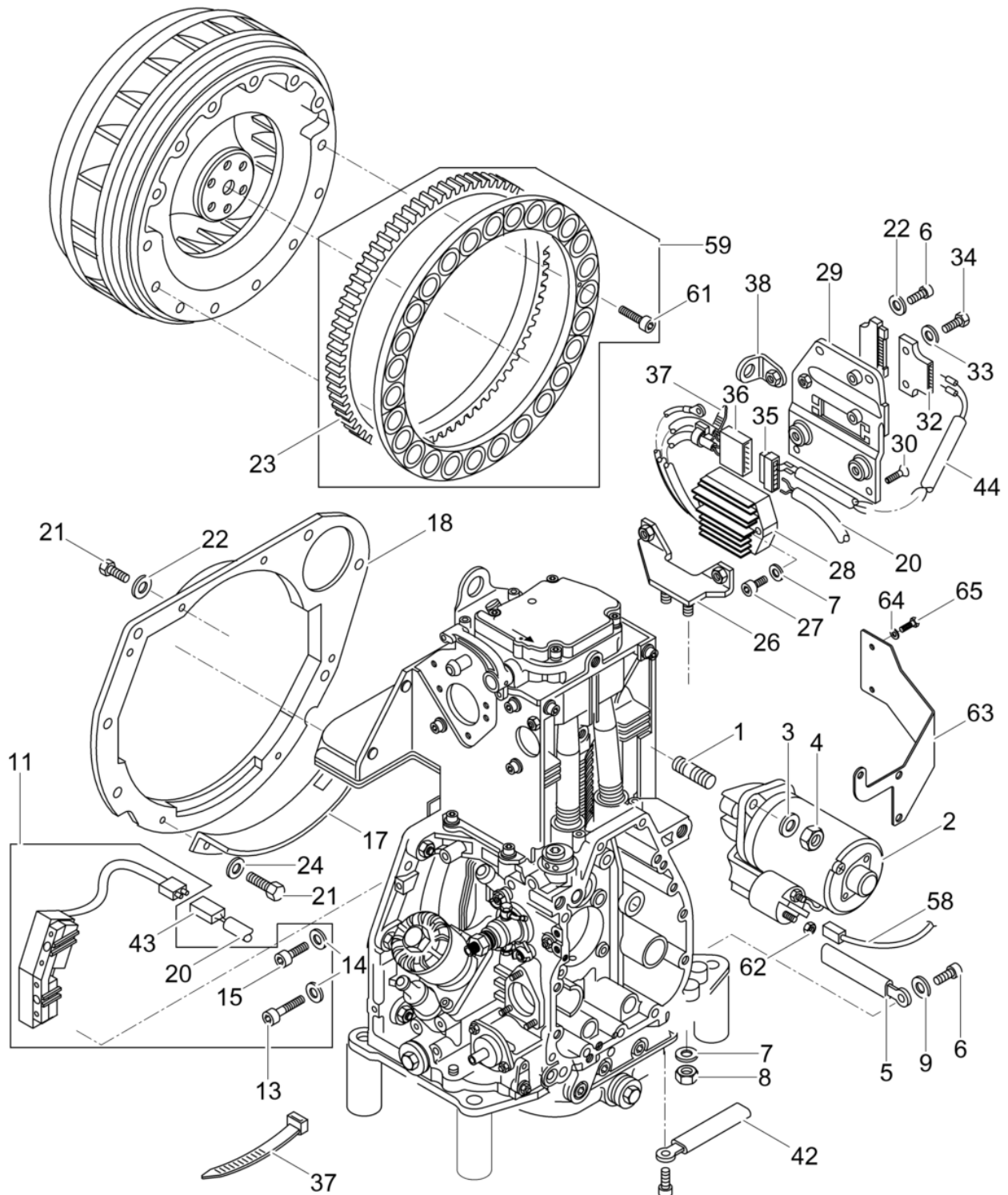

Pos. Item	Artikel Nr. Item no.	Pc.	Unit	Beschreibung Descripción	Description Description	Abm. Dim.	Norm Standard
						Drehmoment Torque	Schmierstoff Lubricant
1	5000203131	2	pc	Gewindebolzen Perno roscado	Threaded bolt Boulon fileté	M12 x 50	
2	5000129769	1	pc	Starter Starter	Starter Starter		
3	5000203132	2	pc	Scheibe Arandela	Washer Rondelle	A13	
4	5000097428	2	pc	Sechskantmutter Tuerca hexagonal	Hexagon nut Écrou hexagonal		
5	5000097590	2	pc	Schelle Abrazadera	Clamp Agrafe		
6	5000151231	1	pc	Zylinderschraube Tornillo cilíndrico	Cheese head screw Vis à tête cylindrique	M6 x 16	ISO4762
7	5000151218	4	pc	Federring Arandela elástica	Lock washer Rondelle de ressort	8	
8	5000151379	2	pc	Sechskantmutter Contratuerca	Locknut Contre-écrou	M8	ISO4032
9	5000151324	1	pc	Scheibe Arandela	Washer Rondelle	6.4	
11	5000097588	1	pc	Spule Bobina	Coil Bobine		
13	5000207612	1	pc	Zylinderschraube Tornillo cilíndrico	Cheese head screw Vis à tête cylindrique	M6 x 40	
14	5000207593	2	pc	Spannscheibe Arandela elástica	Spring washer Disque de serrage		
15	5000203134	1	pc	Zylinderschraube Tornillo cilíndrico	Cheese head screw Vis à tête cylindrique	M6 x 30	
17	5000095068	1	pc	Schutzblech Placa de protección	Guard plate Plaque de protection		
18	5000095067	1	pc	Trennblech Placa	Baffle plate Plaque		
20	5000207562	1	pc	Kabel Cable eléctrico	Electric wire Fil ressortant		
21	5000202436	5	pc	Schraube Tornillo	Screw Vis	M6 x 12	
22	5000151456	4	pc	Federring Arandela elástica	Lock washer Rondelle de ressort	6	DIN128
23	5000096597	1	pc	Zahnkranz Corona dentada	Ring gear Couronne de train planétaire		
24	5000151324	2	pc	Scheibe Arandela	Washer Rondelle	6.4	
26	5000097591	1	pc	Halter Soporte	Holder Attache		
27	5000202440	2	pc	Innensechskantschraube Tornillo a seis lados huecos	Hexagon socket head screw Vis à six pans creux	M8x35	
28	5000212093	1	pc	Reglerschalter Regulador	Regulator Régulateur		
29	5000097592	1	pc	Halteblech Placa	Plate Plaque		
30	5000151387	2	pc	Senkschraube Tornillo avellanado	Countersunk screw Vis noyée	M6 x 12 14Nm/10ft.lbs	ISO10642
32	5000095074	1	pc	Stiftstecker Conector	Connector Connexion		
33	5000129517	2	pc	Scheibe Arandela	Washer Rondelle	A5,3	ISO7089
34	5000207529	2	pc	Zylinderschraube Tornillo cilíndrico	Cheese head screw Vis à tête cylindrique	M5 x 16	

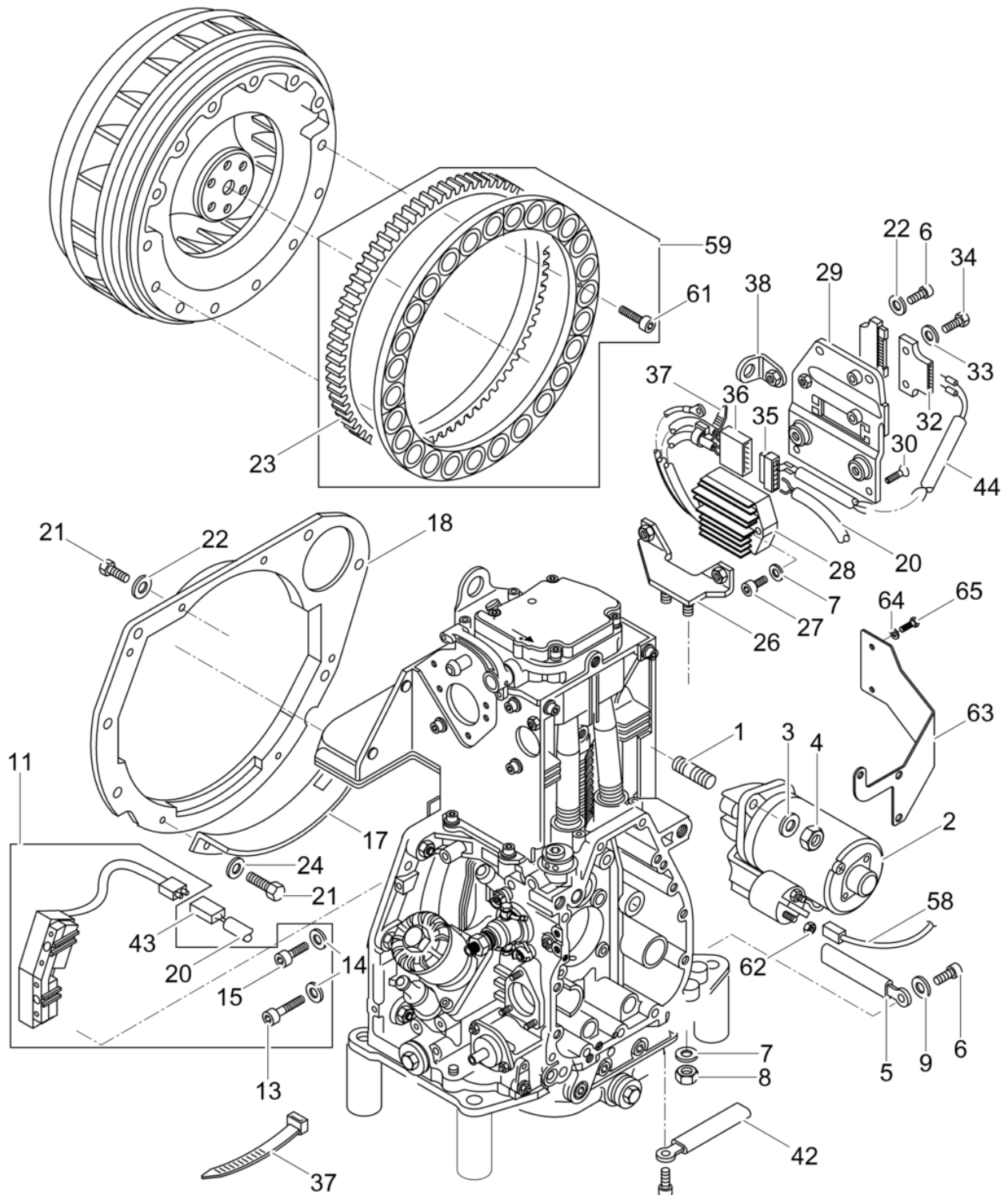

Pos. Item	Artikel Nr. Item no.	Pc.	Unit	Beschreibung Descripción	Description Description	Abm. Dim.	Norm Standard
						Drehmoment Torque	Schmierstoff Lubricant
35	5000099522	1	pc	Steckhülse Tomacorriente	Pin bushing Prise de courant		
36	5000102473	1	pc	Stecker Enchufe	Plug (threaded) Prise		
37	5000109710	4	pc	Kabelbinder Fijación	Tie cable Attache		
38	5000097593	1	pc	Winkel Angulo	Angle Angle		
42	5000102472	2	pc	Schelle Abrazadera	Clamp Collier		
43	5000102471	1	pc	Stecker Enchufe	Plug (threaded) Prise		
44	5000102474	1	pc	Leitung Cable	Cable Câble		
58	5000095075	1	pc	Leitung Cable	Cable Câble		
59	5000107224	1	pc	Magnetring Anillo magnética	Magnetic ring Bague magnétique		
61	5000129026	14	pc	Zylinderschraube Tornillo cilíndrico	Cheese head screw Vis à tête cylindrique	M4 x 16	ISO4762
62	5000108848	1	pc	Mutter Tuerca	Nut Écrou		
63	5000097595	1	pc	Winkel Angulo	Angle Angle		
64	5000129517	2	pc	Scheibe Arandela	Washer Rondelle	A5,3	ISO7089
65	5000207529	2	pc	Zylinderschraube Tornillo cilíndrico	Cheese head screw Vis à tête cylindrique	M5 x 16	

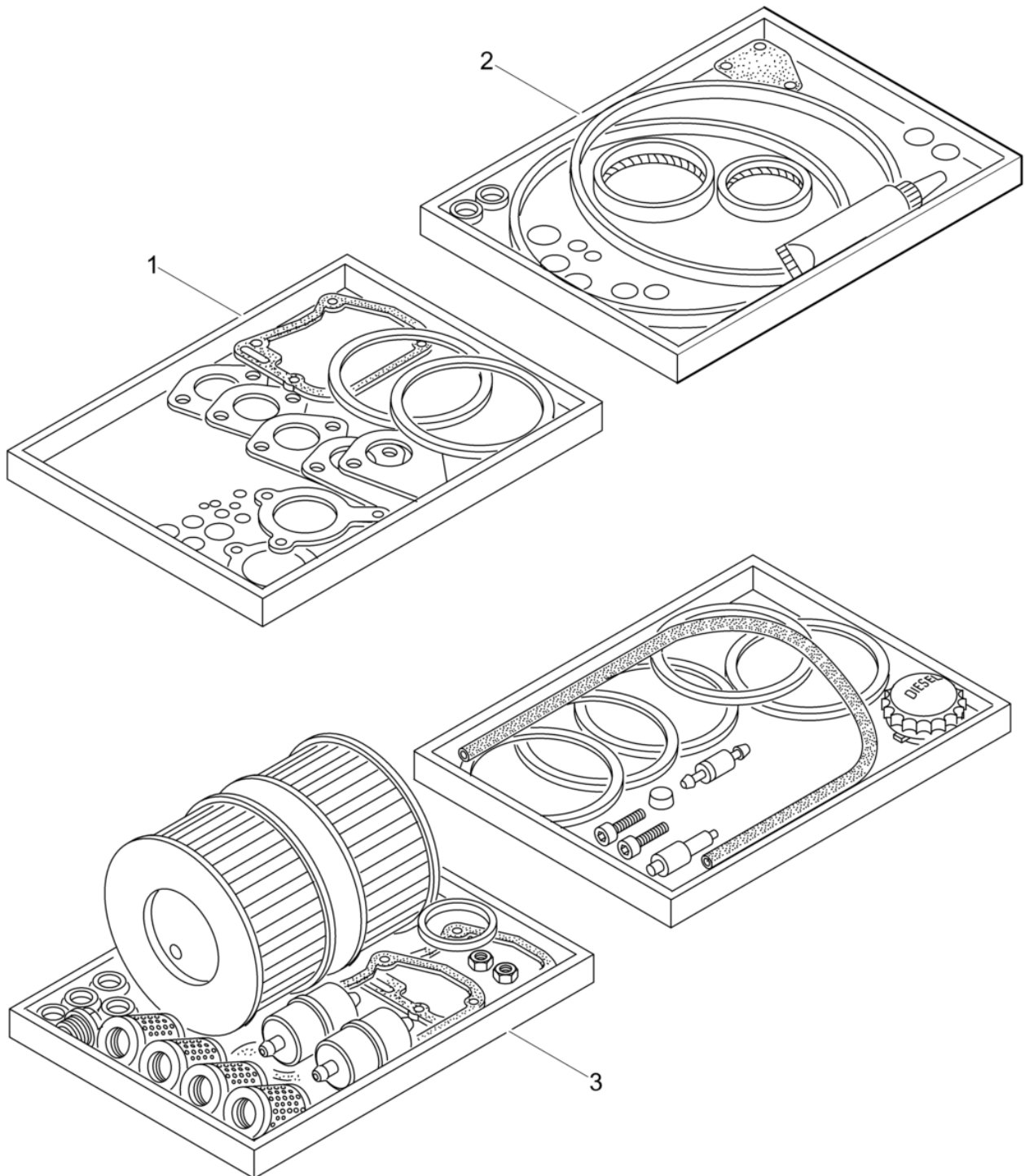

Pos. Item	Artikel Nr. Item no.	Pc.	Unit	Beschreibung Descripción	Description Description	Abm. Dim.	Norm Standard
						Drehmoment Torque	Schmierstoff Lubricant
1	5000105041	1	pc	Dichtungssatz Juego de juntas	Set-gaskets Jeu de joints		
2	5000094878	1	pc	Dichtungssatz-Kurbelgehäuse Juego de juntas-cárter	Set-gasket, crankcase Jeu de joints-carter		
3	5000207606	1	pc	Wartungssatz Juego para mantenimiento	Maintenance set Jeu d'entretien		

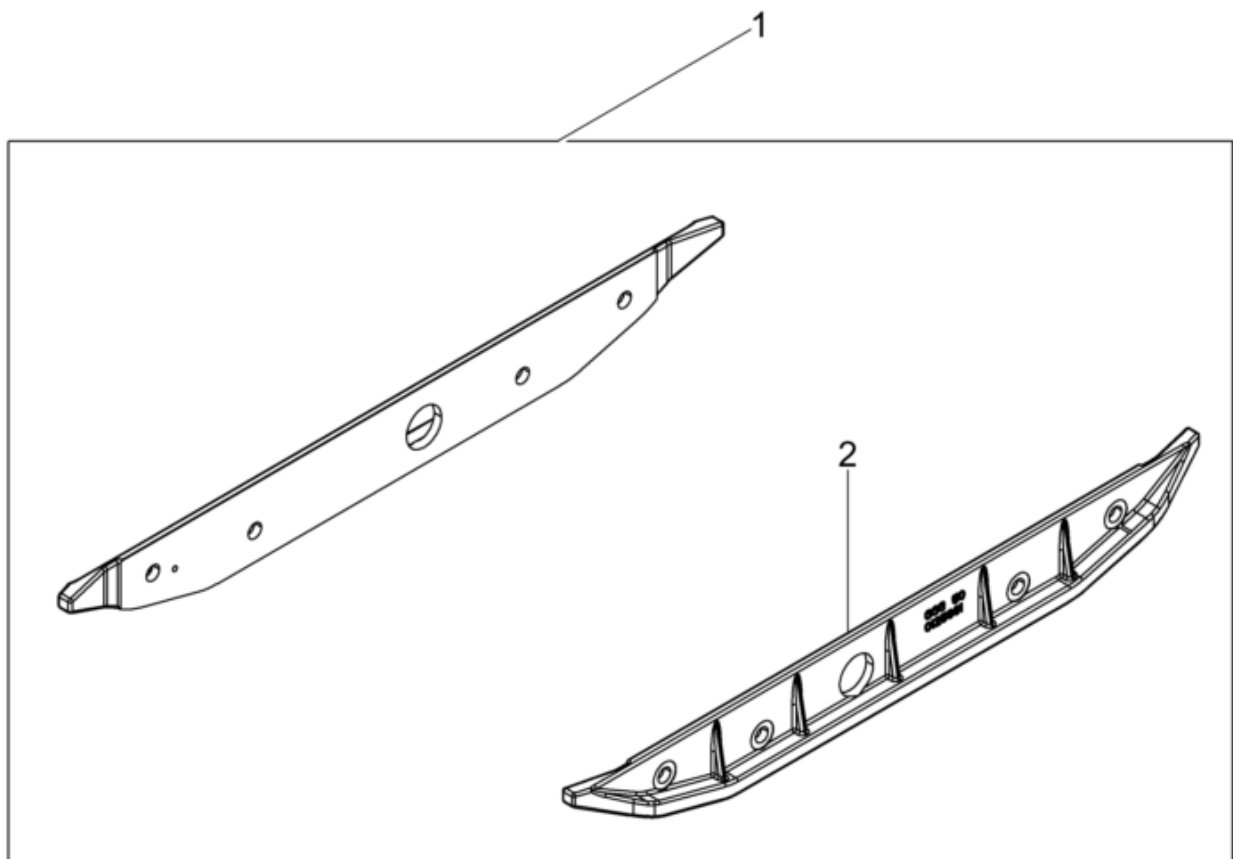

Pos. Item	Artikel Nr. Item no.	Pc.	Unit	Beschreibung Descripción	Description Description	Abm. Dim.	Norm Standard
						Drehmoment Torque	Schmierstoff Lubricant
1	5000126290	1	pc	Anbauplattensatz Juego de placa de extensión	Extension plate kit Jeu de elargisseur	3	
2	5000125662	2	pc	Anbauplatte Placa de extensión	Extension plate Elargisseur	3 cm	

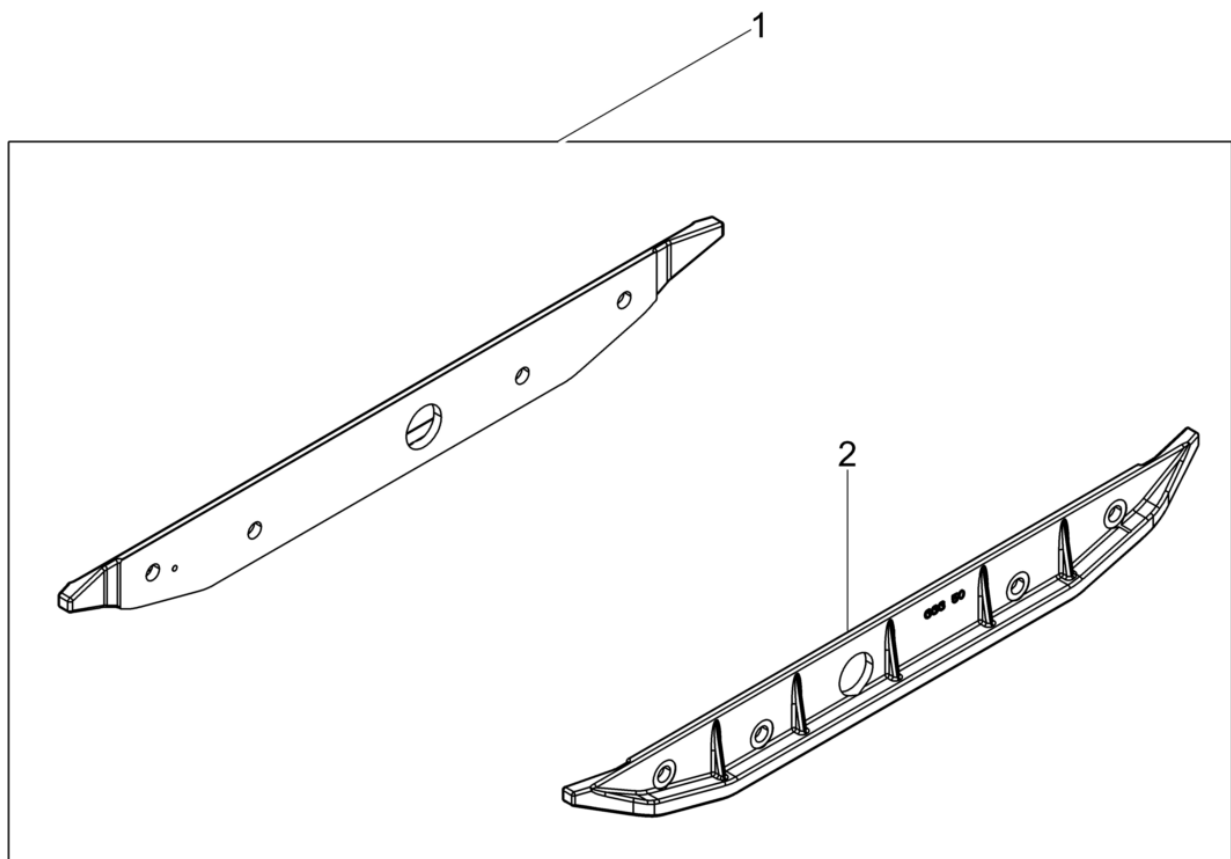

Pos. Item	Artikel Nr. Item no.	Pc.	Unit	Beschreibung Descripción	Description Description	Abm. Dim.	Norm Standard
						Drehmoment Torque	Schmierstoff Lubricant
1	5000045201	1	pc	Anbauplattensatz Juego de placa de extensión	Extension plate kit Jeu de elargisseur	3in	
2	5000044442	2	pc	Anbauplatte Placa de extensión	Extension plate Elargisseur	8 cm	

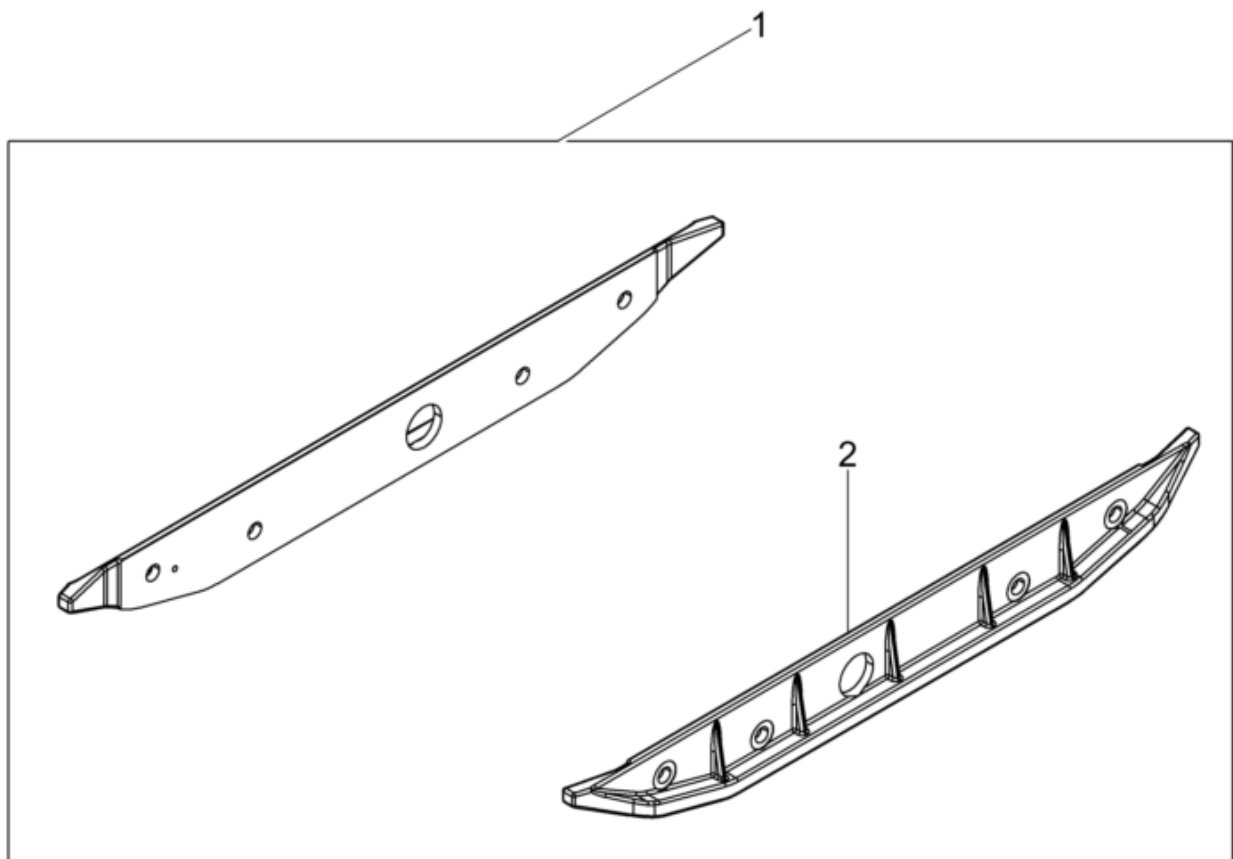

Pos. Item	Artikel Nr. Item no.	Pc.	Unit	Beschreibung Descripción	Description Description	Abm. Dim.	Norm Standard
						Drehmoment Torque	Schmierstoff Lubricant
1	5000043246	1	pc	Anbauplattensatz Juego de placa de extensión	Extension plate kit Jeu de elargisseur	15	
2	5000043245	1	pc	Anbauplatte Placa de extensión	Extension plate Elargisseur	860mm	

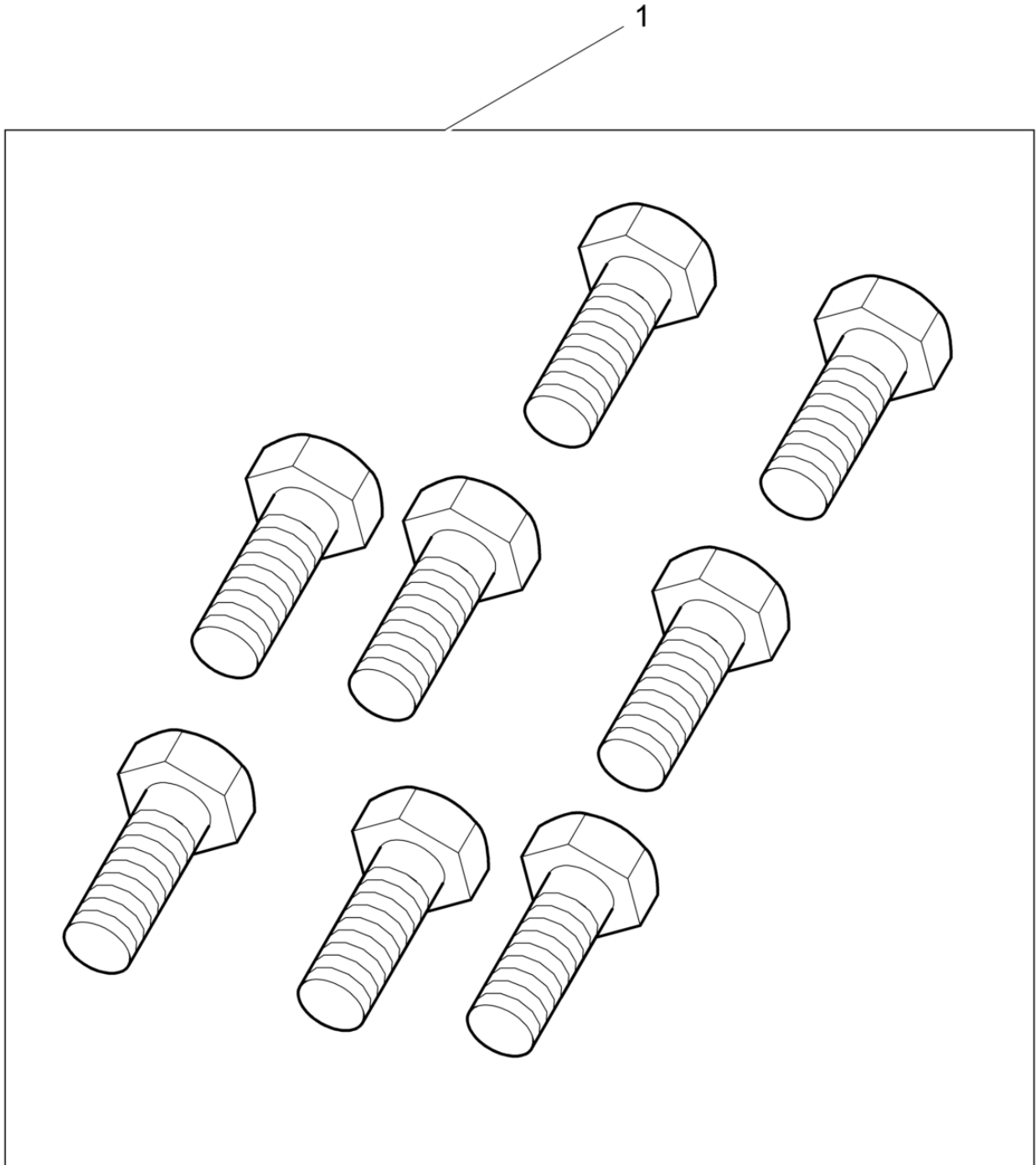

**DPU6555Heh****Schraubensatz  
Set of screws  
Juego de tornillos  
Jeu de vis**

Pos. Item	Artikel Nr. Item no.	Pc.	Unit	Beschreibung Descripción	Description Description	Abm. Dim.	Norm Standard
						Drehmoment Torque	Schmierstoff Lubricant
1	5000067519	1	pc	Schraubensatz Juego de tornillos	Set of screws Jeu de vis		



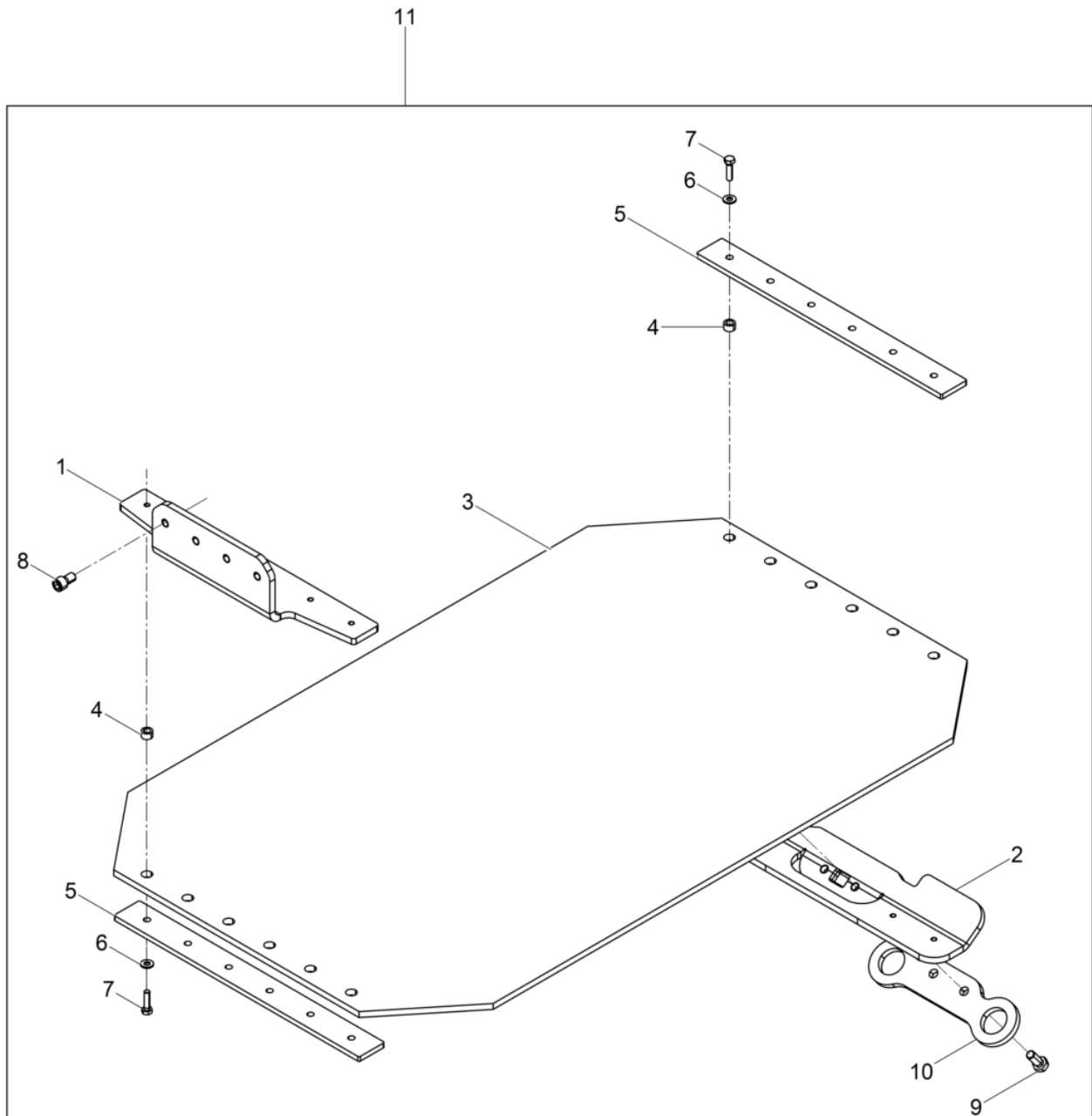

Pos. Item	Artikel Nr. Item no.	Pc.	Unit	Beschreibung Descripción	Description Description	Abm. Dim.	Norm Standard
						Drehmoment Torque	Schmierstoff Lubricant
1	5000205208	1	pc	Winkel Angulo delantera	Front angle Angle de front		
2	5100010936	1	pc	Winkel Hinten Angulo atrás	Angle rear Angle arrière		
3	5000205209	1	pc	Kunststoffplatte Juego de lamina de uretano	Urethane plate Dispositif de glissement		
4	5000047577	10	pc	Buchse Buje	Bushing Douille		
5	5000058358	2	pc	Leiste Listón	Bar Listeau		
6	5000033198	10	pc	Spannscheibe Arandela elástica	Lockwasher Rondelle de ressort	8	DIN6796
7	5000011456	10	pc	Sechskantschraube Tornillo hexagonal	Hexagonal head cap screw Vis à tête hexagonale		
8	5000011531	4	pc	Zylinderschraube Tornillo cilíndrico	Cheese head screw Vis à tête cylindrique	M12 x 20 86Nm/63ft.lbs	ISO4762
9	5000011423	2	pc	Sechskantschraube Tornillo hexagonal	Hexagonal head cap screw Vis à tête hexagonale	M12 x 30 210Nm/155ft.lbs	DIN933
10	5100010935	1	pc	Blech Chapa	Plate Tôle		
11	5100009998	1	pc	Gleitvorrichtung Placa de deslizamiento pgv dpu 6555	Urethane pad kit pgv dpu 6555 Jeu de tapis en polyuréthane		

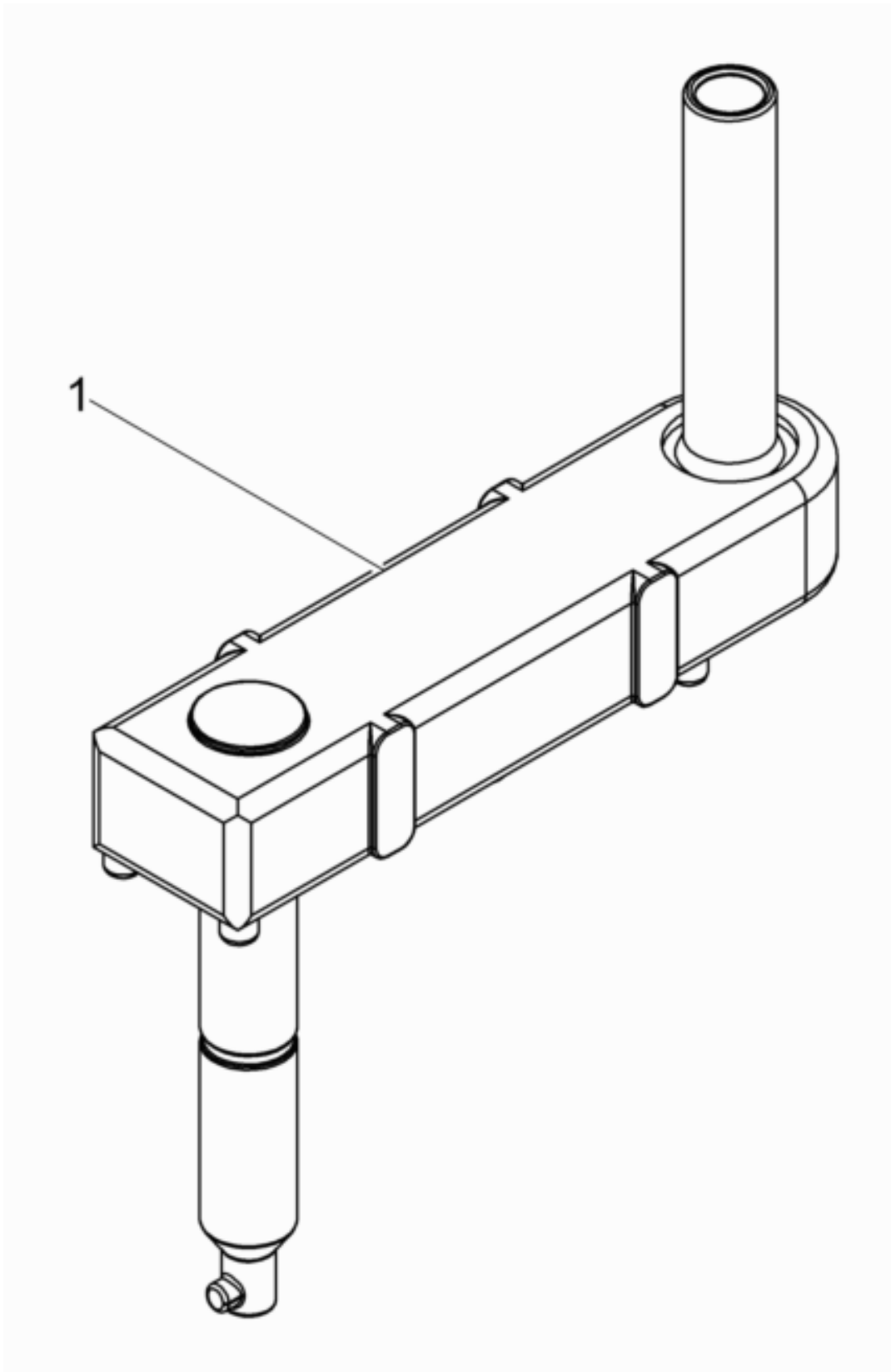

Pos. Item	Artikel Nr. Item no.	Pc.	Unit	Beschreibung Descripción	Description Description	Abm. Dim.	Norm Standard
						Drehmoment Torque	Schmierstoff Lubricant
1	5000095187	1	pc	Andrehkurbel Rückschlagsicher Manivela de arranque	Starting crank Manivelle de démarrage		

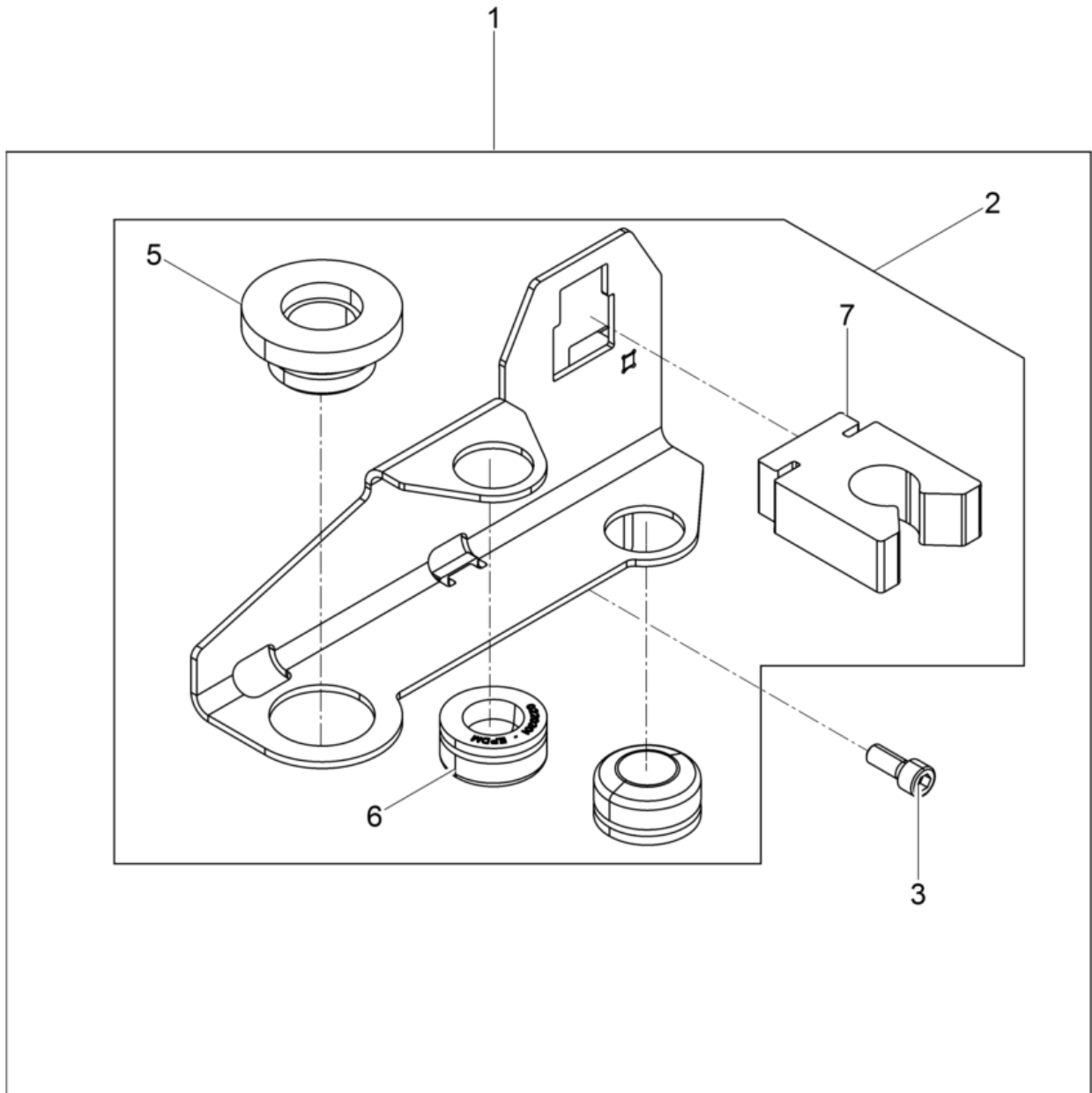

Pos. Item	Artikel Nr. Item no.	Pc.	Unit	Beschreibung Descripción	Description Description	Abm. Dim.	Norm Standard
						Drehmoment Torque	Schmierstoff Lubricant
1	5000220473	1	pc	Anbausatz Juego-instalación-manivela de arranque	Kit-mounting-starting crank Jeu de montage-manivelle de		
2	5100003970	1	pc	Kurbelhalter Kpl. Porta-manivela cpl.	Crank holder cpl. Support manivelle cpl.		
3	5000011535	2	pc	Zylinderschraube Tornillo cilíndrico	Cheese head screw Vis à tête cylindrique		
5	5000220300	1	pc	Gummibuchse Buje	Bush Boîte		
6	5000220301	2	pc	Puffer Amortiguador	Shockmount Silentbloc		
7	5000220239	1	pc	Halterung Soporte	Bracket Équerre		

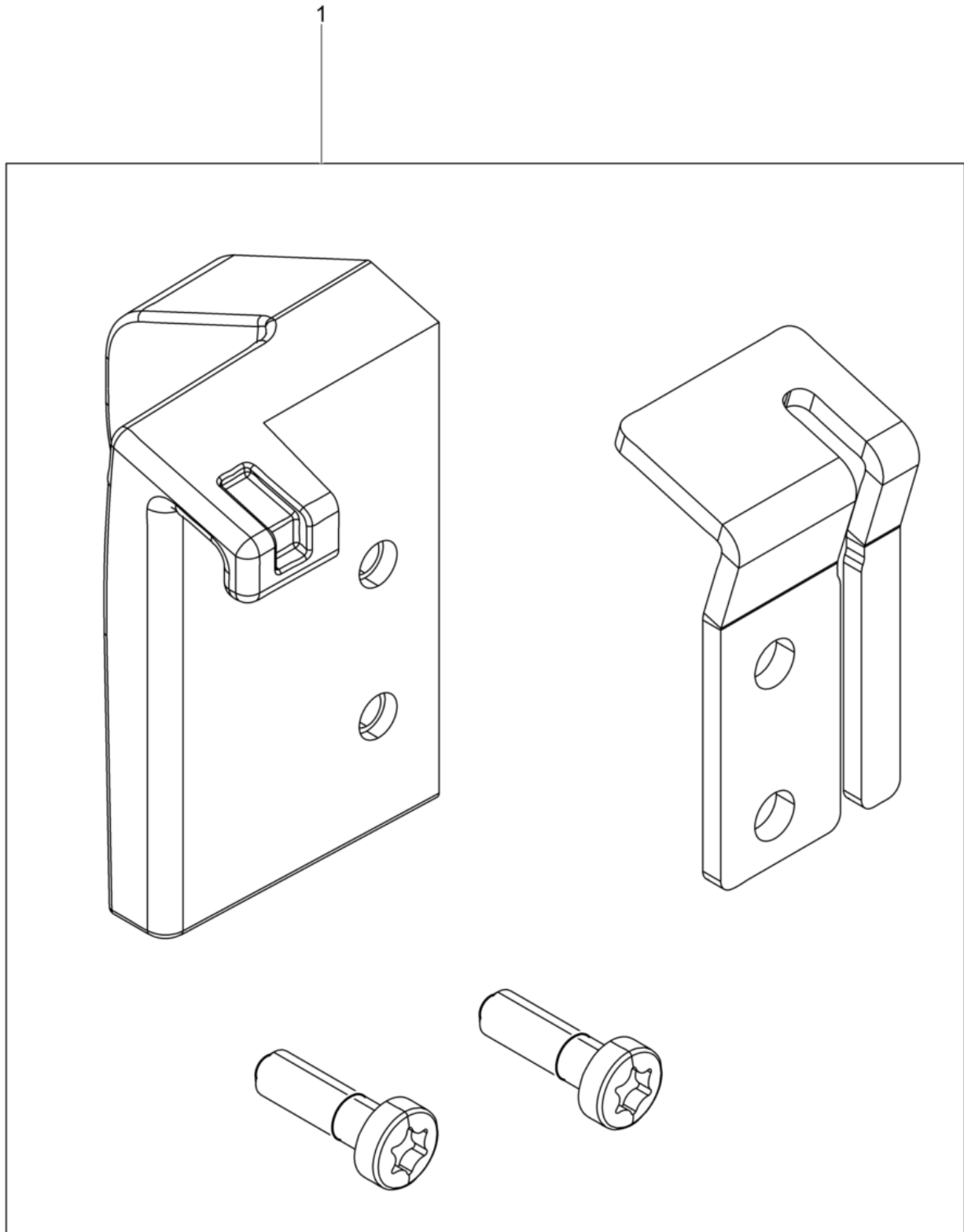

Pos. Item	Artikel Nr. Item no.	Pc.	Unit	Beschreibung Descripción	Description Description	Abm. Dim.	Norm Standard
						Drehmoment Torque	Schmierstoff Lubricant
1	5100005821	1	pc	Nachrüstsatz Riemenberuhiger Juego de modificguía de correa	Kit-retrofit belt guide Lot de rattrapag		

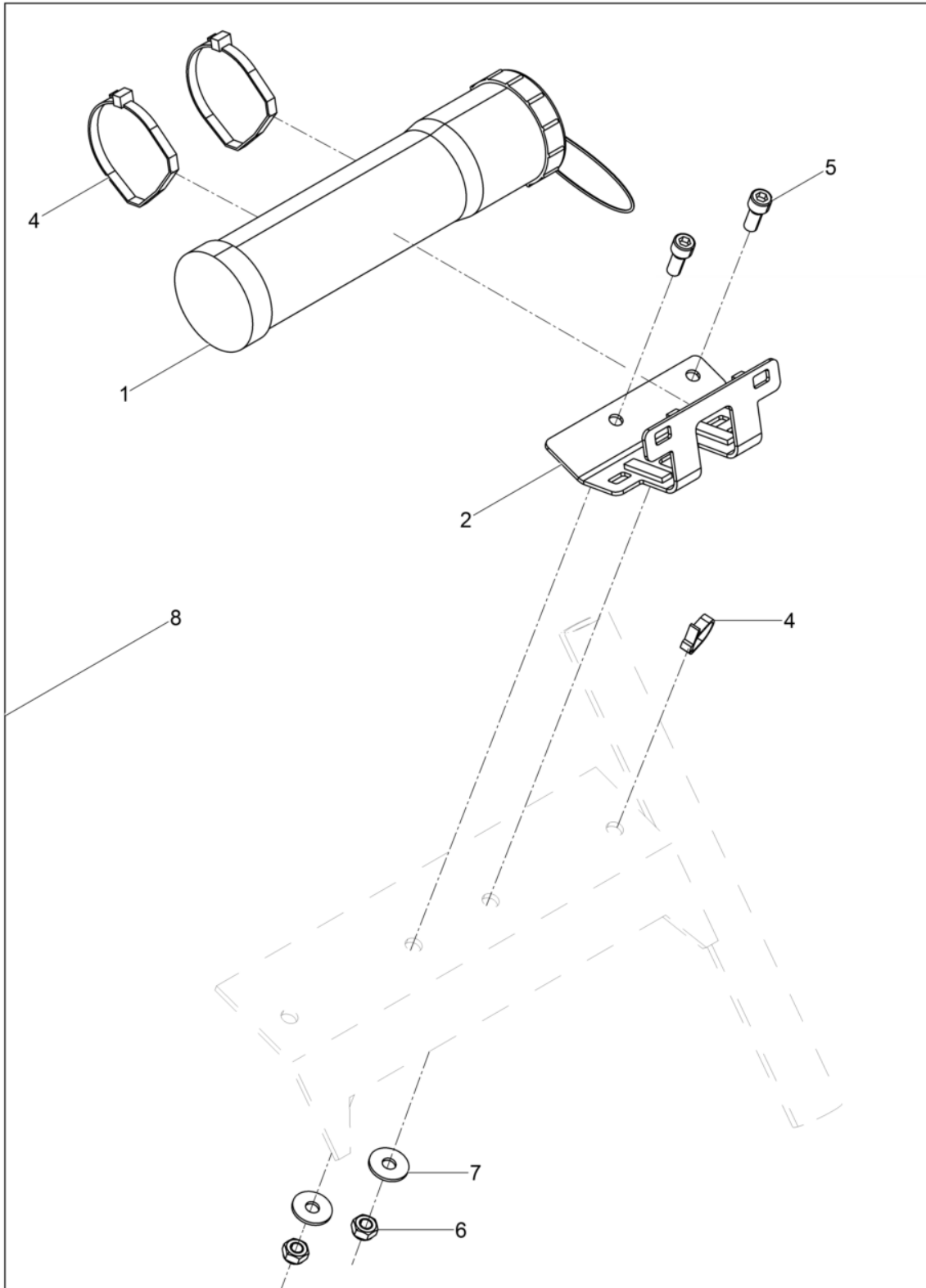

Pos. Item	Artikel Nr. Item no.	Pc.	Unit	Beschreibung Descripción	Description Description	Abm. Dim.	Norm Standard
						Drehmoment Torque	Schmierstoff Lubricant
1	5100026895	1	pc	Dokumentenbehälter Soporte posa documentos	Document-box Receptable de documents		
2	5100027192	1	pc	Halterung Soporte	Bracket Équerre		
4	5000047388	3	pc	Kabelbinder Fijación de cables	Zip tie Attache de câble		
5	5000011535	2	pc	Zylinderschraube Tornillo cilíndrico	Cheese head screw Vis à tête cylindrique	49Nm/36ft.lbs	
6	5000017313	2	pc	Sechskantmutter Tuerca hexagonal	Hexagon nut Écrou hexagonal		
7	5000010375	2	pc	Scheibe Arandela	Flat washer Rondelle	B10,5	DIN9021
8	5100027238	1	pc	Nachrüstsatz Rental DPU6555 Juego de modificación rental dpu6555	Kit-retrofit rental dpu6555 Lot de rattrapage		







**WACKER  
NEUSON**

